

8 Watt Fluorescent Lamp Inverter

Compact DC to AC Inversion for Efficient Lighting Systems

David Bradbury

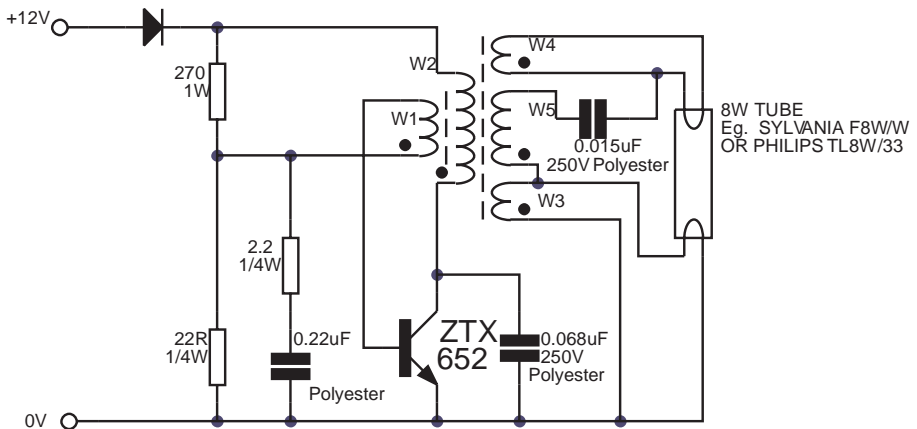

Figure 1
8W Inverter.

The circuit shown in Figure 1 has been designed to drive an 8W fluorescent lamp from a 12V source, using an inexpensive inverter based on the ZTX652 transistor. The inverter will operate from supplies in the range of 10V to 16.5V, attaining efficiencies up to 78% thus making it suitable for use in on-charge systems such as caravans / mobile homes/ RVs as well as periodically charged systems such as roadside lamps, camping lights or outhouse lights etc. Other features of the inverter are that it oscillates at an inaudible 20kHz and that it includes reverse polarity protection.

Circuit Operation

The 270Ω and 22Ω resistors bias a ZTX652 transistor into conduction, where the positive feedback given to the transistor by W1 drives it into saturation, thus applying the supply voltage across W2. This causes a magnetising current to build up in W2 until the transformer's ferrite core saturates. When this happens, the base drive given to the transistor by W1 decays, causing the transistor to rapidly turn off.

Until the fluorescent tube strikes, the transformer is only loaded by the tube heater filaments which present only a minimal load. Thus when the transistor

turns off the transformer 'rings' for half a cycle at a frequency governed by the windings' inductance and the 0.068 μ F capacitor, reversing the magnetising current and turning the transistor on again. This 'ring' induces a high voltage pulse across the fluorescent tube which will cause it to strike once the heaters have warmed up.

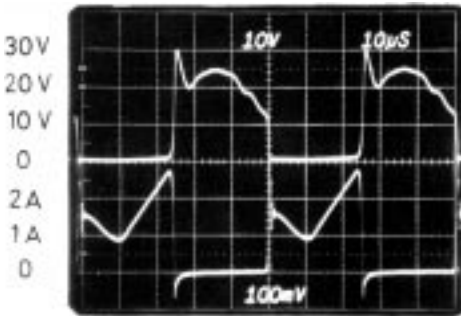

Figure 2
ZTX652 V_{CE} and I_E waveforms.

Once the tube has struck, it loads the transformer heavily, swamping this ringing action and so greatly reducing the peak voltage induced across W2 and the transistor. This extends the non-conducting period of the inverter cycle and during this period, energy stored in the transformer in the form of magnetising current is dumped into the fluorescent tube. When all of this energy has been dumped, the voltage on the transistor collector falls and it switches on once more.

The voltage required to pass current through the tube has now fallen enough for it to conduct during both half cycles of inverter oscillation. Thus when the transistor now turns on, it both drives

the fluorescent tube directly and also stores energy in the transformer which drives the tube during the transistor's non-conducting period. The current passed through the tube is controlled by the transformer's leakage inductance and also a series connected 0.015 μ F capacitor. Waveforms of the transistor's collector voltage and emitter current under normal operating conditions are given in Figure 2.

The 2.2 Ω resistor and 0.22 μ F capacitor included in the circuit give the inverter a rapid turn-off characteristic, which limits the power dissipation in the transistor to approximately 500mW with the tube lit and with a 12V supply. However the power dissipation in the transistor is much higher if the tube is broken or removed. Taking the worst case conditions of 16.5V supply and no tube, the transistor will dissipate approximately 1.5W. Thus if the inverter may be operated under these conditions as for instance Public Transport applications etc., the transistor should be clamped to a heatsink better than 15 °C/W.

Where the inverter will not remain energised if the tube does not strike, no heatsink is necessary.

Similar higher power designs are possible using the ZTX853 4A DC rated part, which is available in the E-Line package, (enhanced TO92) and also in the surface mount SOT223 package as the FZT853.

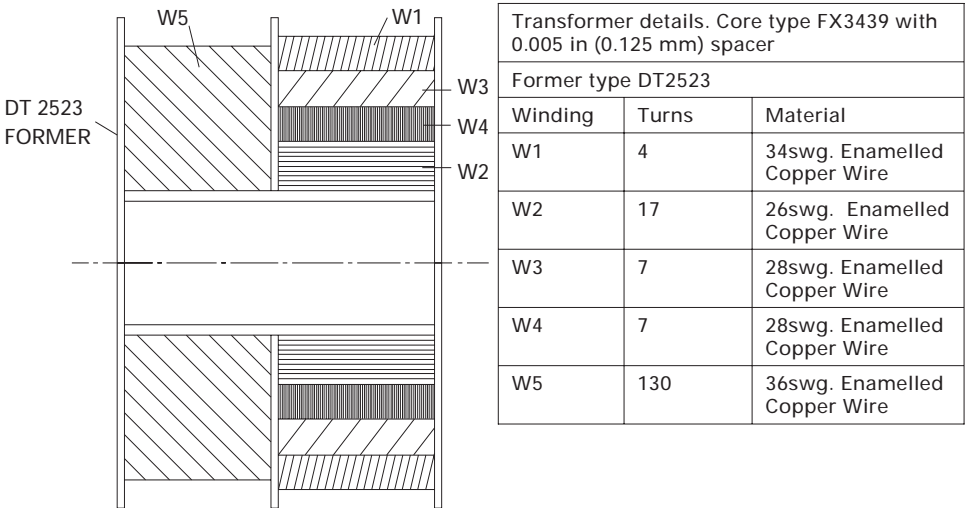

Figure 3
Transformer winding detail.

Construction

Apart from keeping component lead lengths short, the layout of the circuit is not critical. Care should be taken however in winding the transformer (see figure 3). It is advisable to mount the unit in a metal case as this will provide RF screening of the inverter and also provides a ground plane for the fluorescent tube which significantly reduces its striking voltage. The case could also be used as heatsinking for the ZTX652 transistor when required.