

## Contents

1. Features
2. Introduction
3. Regulator Design Procedure
4. Design Example

## 1.0 Features

- ◆ Small Board Size
  - Entire circuit can fit in less than 1 square inch of PCB space
- ◆ Low Implementation Cost
  - Fewer than 4 discrete components required
- ◆  $\overline{ON}$ /OFF Control
  - Be controlled by external logic level signal
- ◆ Thermal Shut-down and Current Limit
  - Built-in function
- ◆ Simple Feedback Compensation
  - Lead compensation using external capacitor
- ◆ Immediate Implementation
  - Schematic, board-of-materials and board layout available from Anachip

## 2.0 Introduction

This application note discusses simple ways to select all necessary components to implement a step-down (BUCK) regulator and gives a design example. In this example, the AP1509 monolithic IC is used to design a cost-effective and high-efficiency miniature switching buck regulator. Please refer to the datasheet for more complete information, pin descriptions and specifications for the AP1509 will not be repeated here.

This demonstration board allows the designer to evaluate the performance of the AP1509 series buck regulator in a typical application circuit. The user needs only to supply an input voltage and a load. The demonstration board can be configured to evaluate fixed output voltages of 3.3V, 5V, 12V, and an adjustable output version of the AP1509 series. Operation at other voltages and currents may be accomplished by proper component selection and replacement.

### 3.0 Regulator Design Procedure

#### 3.0.1 Given Power Specification

$V_{IN(max)}$  = Maximum Input Voltage

$V_{IN(min)}$  = Minimum Input Voltage

$V_{OUT}$  = Regulated Output Voltage

$V_{RIPPLE}$  = Ripple Voltage (peak to peak), typical value is 1% of the Output Voltage

$I_{LOAD(max)}$  = Maximum Load Current

$I_{LOAD(min)}$  = Minimum Load Current before the circuit becomes discontinuous, typical value is 10% of the Maximum Load Current

$F$  = Switching Frequency (fixed at a nominal 150kHz)

#### 3.0.2 Programming Output Voltage (refer to 4.0.4 Demo Board Schematic P7)

The Output Voltage is programmed by selection of the divider R1 and R2. The designer should use resistors R1 and R2 with  $\pm 1\%$  tolerance in order to obtain best accuracy of the Output Voltage. The Output Voltage can be calculated from the following formula:

$$V_{out} = 1.23 \times (1 + R1 / R2)$$

Select a value for R2 between 240 $\Omega$  and 1.5K $\Omega$ . The lower resistor values minimize noise pickup in the sensitive feedback pin.

If the designer selects a fixed output version of the AP1509, the resistor R1 shall be short and R2 shall be open.

**3.0.3 Inductor Selection**

A. The minimum inductor  $L_{(min)}$  can be calculated from the following design formula table:

Calculation	Step-down (buck) regulator
$\frac{T_{ON}}{T_{OFF}}$	$\frac{(V_{OUT} + V_F)}{V_{IN(min)} - V_{SAT} - V_{OUT}}$
$L_{(min)}$	$\frac{[V_{IN(min)} - V_{SAT} - V_{OUT}] \times T_{ON(max)}}{2 \times I_{LOAD(min)}}$

$V_{SAT}$  = Internal switch saturation voltage of the AP1509 = 1.25V

$V_F$  = Forward voltage drop of output rectifier D1 = 0.5V

B. The inductor must be designed so that it does not saturate or significantly saturate at DC current bias of  $I_{PK}$ . ( $I_{PK}$  = Peak inductor or switch current =  $I_{LOAD(max)} - I_{LOAD(min)}$ )

**3.0.4 Output Capacitor Selection**

A. The output capacitor is required to filter the output and provide regulator loop stability. When selecting an output capacitor, the important capacitor parameters are; the 100kHz Equivalent Series Resistance (ESR), the RMS ripples current rating, voltage rating, and capacitance value. For the output capacitor, the ESR value is the most important parameter. The ESR can be calculated from the following formula:

$$ESR = \left( \frac{V_{RIPPLE}}{2 \times I_{LOAD(min)}} \right) \text{----- (3)}$$

An aluminum electrolytic capacitor's ESR value is related to the capacitance and its voltage rating. In most cases, higher voltage electrolytic capacitors have lower ESR values. Most of the time, capacitors with much higher voltage ratings may be needed to provide the low ESR values required for low output ripple voltage. If the selected capacitor's ESR is extremely low, it results in an oscillation at the output. It is recommended to replace this low ESR capacitor by using two general standard capacitors in parallel.

B. The capacitor voltage rating should be at least 1.5 times greater than the output voltage, and often much higher voltage ratings are needed to satisfy the low ESR requirements needed for low output ripple voltage.

#### 3.0.5 Output Rectifier Selection

- A. The Output Rectifier D1 current rating must be greater than the peak switch current  $I_{PK}$ . The reverse voltage rating of the output rectifier D1 should be at least 1.25 times the maximum input voltage.
- B. The output rectifier D1 must be fast (short reverse recovery time) and must be located close to the AP1509 using short leads and short printed circuit traces. Because of their fast switching speed and low forward voltage drop, Schottky diodes provide the best performance and efficiency, and should be the first choice, especially in low output voltage applications.

#### 3.0.6 Input Capacitor Selection

- A. The RMS current rating of the input capacitor can be calculated from the following formula table. The capacitor manufacturers datasheet must be checked to assure that this current rating is not exceeded.

Calculation	Step-down (buck) regulator
$\delta$	$T_{on}/(T_{on}+T_{off})$
$I_{PK}$	$I_{LOAD(max)} + I_{LOAD(min)}$
$I_m$	$I_{LOAD(max)} - I_{LOAD(min)}$
$\Delta I_L$	$2 \times I_{LOAD(min)}$
$I_{IN(rms)}$	$\sqrt{\delta \times \left[ (I_{PK} \times I_m) + \frac{1}{3} (\Delta I_L)^2 \right]}$

- B. This capacitor should be located close to the IC using short leads and the voltage rating should be approximately 1.5 times the maximum input voltage.

### 3.0 Design Example

#### 4.0.1 Summary of Target Specifications

Input Power	$V_{IN(max)} = +12V; V_{IN(min)} = +12V$
Regulated Output Power	$V_{OUT} = + 3.3V; I_{LOAD(max)} = 2A; I_{LOAD(min)} = 0.2A$
Output Ripple Voltage	$V_{RIPPLE} \leq 50 \text{ mV peak-to-peak}$
Output Voltage Load Regulation	1% (1/2 full load to full load)
Efficiency	75% minimum at full load
Switching Frequency	$f = 150kHz \pm 15 \%$

### 4.0.2 Calculating and Components Selection

Calculation Formula	Select Condition	Component spec.
$V_{out} = V_{ref} \times ((R1/R2) + 1)$	$240\Omega \leq R2 \leq 1.5K\Omega$	R1 = 560Ω; R2 = 330Ω
$L_{(min)} \geq \frac{[V_{IN(min)} - V_{SAT} - V_{OUT}] \times T_{ON(max)}}{2 \times I_{LOAD(min)}}$ $I_{PK} = I_{LOAD(max)} - I_{LOAD(min)}$	$L_{(min)} \geq 38\mu H$ $I_{rms} \geq I_{PK} = 1.8A$	Select L1 = 39uH
$ESR = \left( \frac{V_{RIPPLE}}{2 \times I_{LOAD(min)}} \right)$ $V_{WVDC} \geq 1.5 \times V_{OUT}$	$ESR \leq 125m\Omega$ $V_{WVDC} \geq 7.5V$	Select C3: 1000uF/10V*1pcs
$V_{RRM} \geq 1.25 \times V_{IN(max)}$ $I_{PK} = I_{LOAD(max)} + I_{LOAD(min)}$	$V_{RRM} \geq 15V$ $I_{PK} = 1.8A$	Select D1: 20V/2A
$I_{IN(rms)} = \sqrt{\delta \times \left[ (I_{PK} \times I_m) + \frac{1}{3} (\Delta I_L)^2 \right]}$ $V_{WVDC} \geq 1.5 \times V_{IN(max)}$	$I_{ripple} \geq I_{IN(rms)} = 1A$ $V_{WVDC} \geq 18V$	Select C1: 330uF/35V*1pcs

### 4.0.3 Parts List (Board of Materials)

Item	Part Number	MFG/Dist.	Description	Value	Quantity
C1		OST	Aluminum Electrolytic	330uF, 35V	1
C2	0805 cap	Viking	Ceramic Capacitor	0.1uF, 25V	1
C3		OST	Aluminum Electrolytic	1000uF, 10V	1
C4	0805 cap	Viking	Ceramic Capacitor	0.1uF, 25V	1
D1	220		Schottky Diode	20V, 2A	1
J1			Jumper	Pitch = 2.54mm, 3pin	1
J2,J3			Pin		2
L1			Inductor	39uH, 1.8A	1
U1	AP1509	Anachip	PWM Buck Converter	150kHz, 2A	1
R1	0805 reg	Viking	Film Chip Resistor	560Ω	1
R2	0805 reg	Viking	Film Chip Resistor	330Ω	1

### 4.0.4 Demo Board Schematic

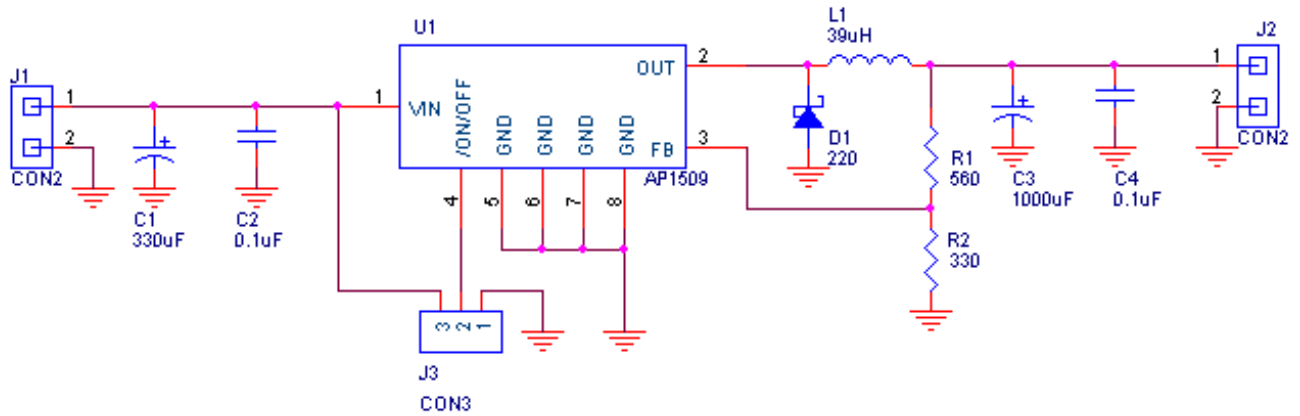

### 4.0.5 Demo Board Efficiency and Temperature

Load	Efficiency	IC body temp.	IC pad temp.	Diode temp.	L temp.
0.5A	87.05%	31.5	35	31	30
1A	84.49	32.8	37	32.3	31
1.5A	82.55	35	43	33	32
2A	81.50%	43	50.9	36	34.3
2.5A	80.55	49	57	41	38
3A	79.02	52	60	45	40.5
Short		33	36	49	41

**4.0.6 Typical PC Board Layout**



**(1). Component Placement Guide**

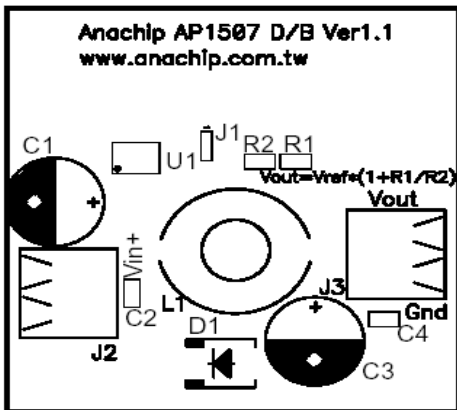



**(2). Component Side PC Board Layout**

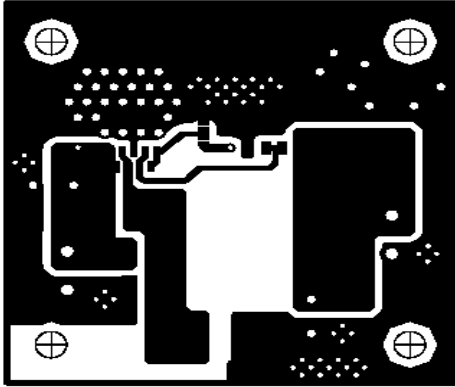

**(3). Solder Side PC Board Layout**

