

Contents

1. Background
2. General Description
3. Application Information

Application Note

Hall Effect Latch Switch

1.0 Background

In general applications, the Hall IC operates on magnetic pole switching. As the magnetic flux direction changes, the Hall switch is turned on and off. On ring magnets, both south and north poles are present in alternating patterns. The release point flux density becomes less important than if the Hall switch has not turned off as the flux density to be zero. It will turn off when the following north pole causes the flux density to be negative. Bipolar Hall switches take advantage of this extra margin in release point flux values to achieve lower operation point flux densities. That is a definite advantage in ring magnet applications.

2.0 General Description

ATS236, ATS276, ATS277 are a series of Hall effect latch switches which are integrated Hall sensors with two output drivers, typically designed for electronic commutation of two-phase brush-less DC Fan applications. The on-chip Hall sensor will generate Hall voltage due to magnetic sensing. The amplifier will amplify the Hall voltage. The Schmitt trigger determines switching hysteresis and then controls internal driver's on/off to sink load current. Meanwhile, an internal band-gap regulator is used to provide stable bias due to temperature-compensation.

If a magnetic flux density larger than threshold Bop, DO is turned on (low) and DOB is turned off (high), the output state is held until a magnetic flux density reversal falls below Brp causing DO to be turned off and DOB turned on.

3.0 Application Information

3.1 Magnetic Induction

The Hall switch is located in a position to sense the magnetic field. The vane width and the steepness of the magnetic slope, which is by the operate and release point flux density value for the switch to determine that the interval during "off" time of Hall switch. In datasheet ATS236, ATS276, and ATS277 series, hysteresis, operate and release points are defined. The user shall make sure that the Hall switch can operate in latch to select the parts. If necessary, please locate the contact information for the right grade of Hall switch. The hysteresis, operate and release point could be assigned for each item to get a higher grade to guarantee the magnetic induction.

Some mechanical issues have to be verified to offer enough start up torque. The induction distance and magnetic intensity of the coil core are the major items. Sensor position is another parameter to decide the magnetic induction performance. Two or more degrees of sensing are useful for magnetic induction assurance. The sensor position is pointed out in the datasheet.

3.2 Operation

3.2.1 Minimum Voltage Operation

The minimum operation voltage is defined for Hall switch (IC) operation. In practicality, the minimum fan operation shall cover the voltage across the coil and other extra components (i.e. external diode). The minimum current shall be confirmed high enough to drive the fan to rotation. Check the coil resistor to make sure of start up.

Application Note
Hall Effect Latch Switch

3.2.2 Maximum Voltage Operation

The Hall switch maximum operation voltage is limited by the driver saturation voltage and IC body impedance. There is a voltage spike from the inductor leakage impact as switching. Internal zener diode could clamp the voltage spike to protect the driver, but the application could be more reliable if a good magnetic design reduced the leakage inductance.

3.2.3 Clamping Capacitor

Sometimes, adding capacitors in DO (pin 2) and DOB (pin 3) can reduce the voltage spike as Fig.-1 shows. This application has a negative impact that a high current spike may damage the driver. As Fig.-2 shows, we recommend that you add a capacitor in V_{CC} or coil common point to clamp the voltage spike.

Generally, The capacitor value may be 1uF to 4.7uF, which has to be confirmed in an application fan how amplitude would be reduced.

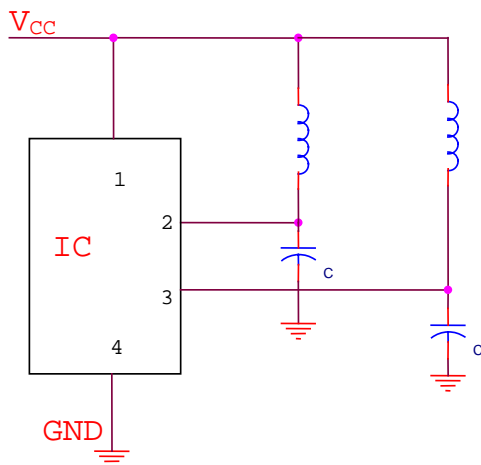

Fig.-1 Clamping Capacitors with High Current Spike

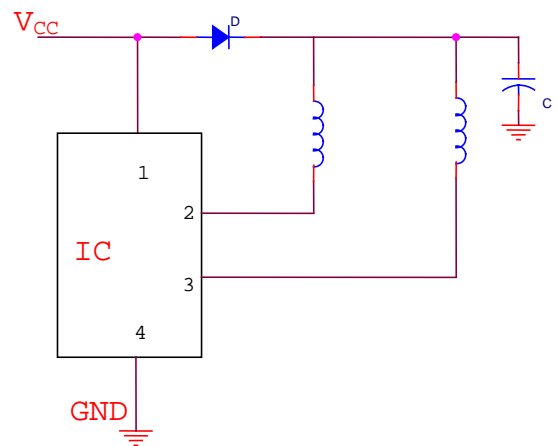

Fig.-2 Recommended Clamping Capacitor

Application Note

Hall Effect Latch Switch

3.3 Driver Capability

Driving the current in coil is the main function of Hall switches. The driver capability has to be confirmed by the operation, hold and peak current, which are defined in the datasheet.

The coil may be damaged if held a longer time. The hold current is greater than the operation current, which will cause the coil temperature to go up and make the coil malfunction. The second breakdown will happen on the driver and possibly also on this higher temperature condition. The operation current is designed for fan speed, and the coil impedance is the major parameter. Being the driver BJT, the current through the coil is pre-driven by the base current in the driver, so the driving current is limited. This driver capability should be checked that the BJT operation on an SOA (Safe Operating Area) from the current and voltage switching waveform to assure the driving life performance.

There are two parameters that shall be verified for maximum driver operation: I_c operation current and P_d (Power Dissipation), the I_c is also defined in the datasheet. Even the I_c operates within the datasheet definition, the P_d is another item which shall be verified as $P_d = I_{cc} * V_{cc} + I_c * V_{ce(SAT)}$, generally.

For example of ATS277, the I_c (continuous) is max. 400mA, P_d is max. 550mW.

Case 1. $I_c = 380$ mA, and $V_{cc} = 5$ V, then,
 I_c is within spec. and $P_d = 14 * 5 + 380 * 1.0 = 450$ (mW), also in spec.

Case 2. $I_c = 380$ mA, and $V_{cc} = 14$ V, then,
 I_c is within spec., but $P_d = 14 * 14 + 380 * 1.0 = 636$ (mW), out of spec., driver will fail at this condition.

From the above description, the driver can stand the maximum operation current until P_d is out of maximum dissipation. So, not only check I_c but also confirm that the P_d is necessary.

3.4 Reverse Protection

For DC fan applications, it is sometimes necessary to test the power reverse connection condition. The internal diode only protects the chip-side. If necessary, add one external diode as Fig.-2 shows to block the reverse current from the coil-side.