

DOCUMENT CONTROL NO.  
PD - 1203

REVISION: H  
DATE: 10/22/07

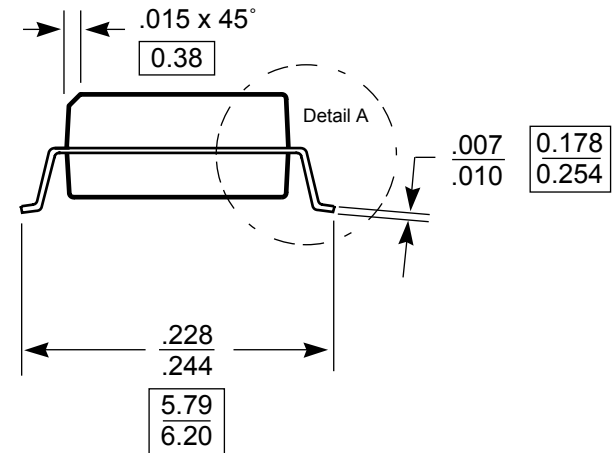
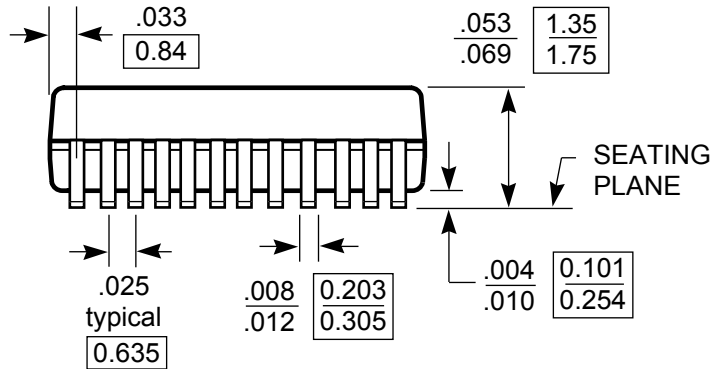
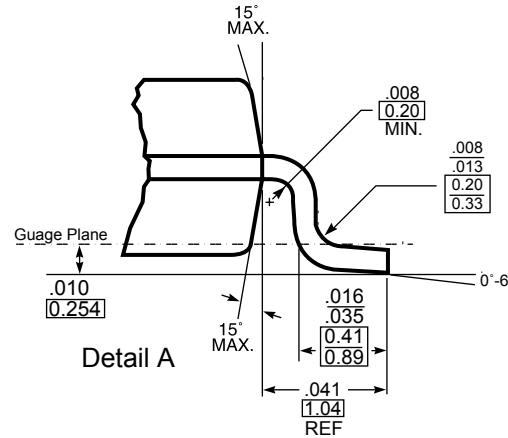
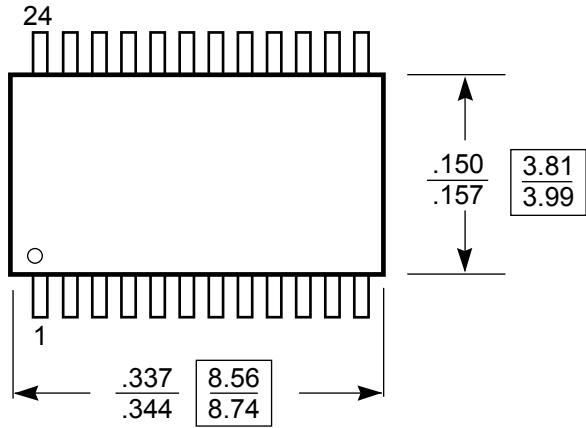

X.XX DENOTES DIMENSIONS  
X.XX IN MILLIMETERS

Note:  
 1) Controlling dimensions in millimeters  
 2) Ref: JEDEC MO-137B/AE  
 3) Dimensions do not include mold flash, protrusions or gate burrs



Pericom Semiconductor Corporation  
 3545 N. 1st Street, San Jose, CA 95134  
 1-800-435-2335 • www.pericom.com

DESCRIPTION: 24-Pin, 150-Mil Wide, QSOP

PACKAGE CODE: Q