

DOCUMENT CONTROL NO.
PD - 1202

REVISION: H
DATE: 10/22/07

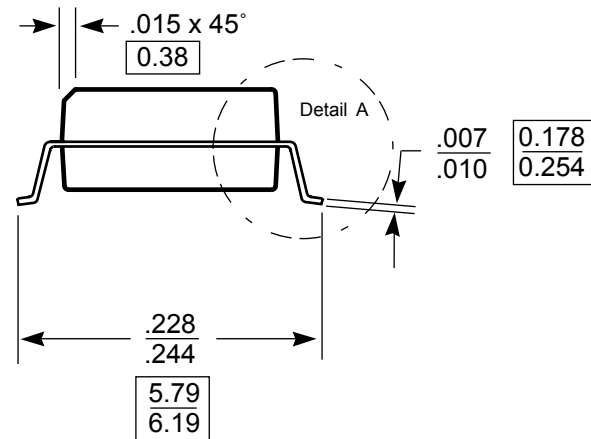
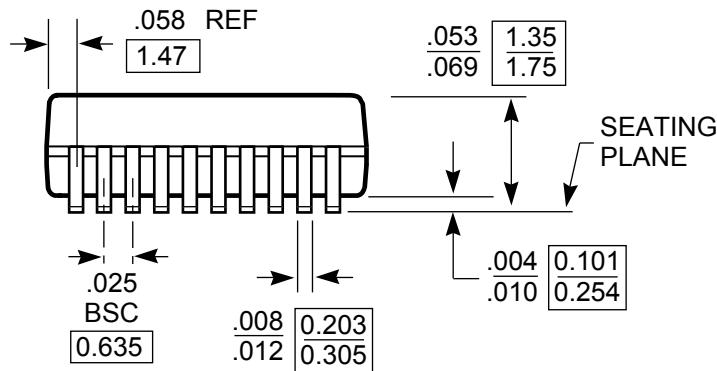
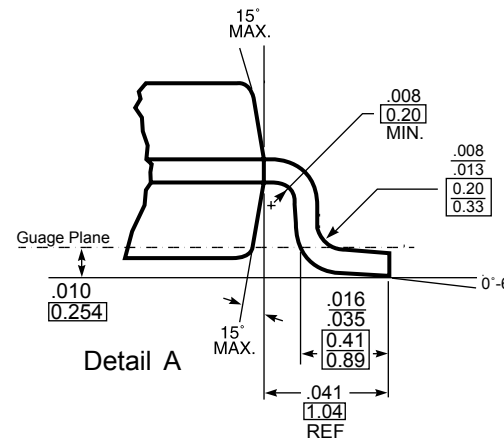
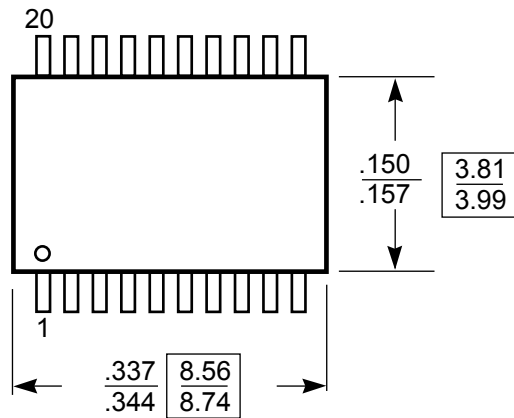

$\frac{X.XX}{X.XX}$ DENOTES DIMENSIONS
IN MILLIMETERS

Note:

- 1) Controlling dimensions in inches.
- 2) Ref: JEDEC MO-137B/AD
- 3) Dimensions do not include mold flash, protrusions or gate burrs



Pericom Semiconductor Corporation
3545 N. 1st Street, San Jose, CA 95134
1-800-435-2335 • www.pericom.com

DESCRIPTION: 20-Pin, 150-Mil Wide, QSOP

PACKAGE CODE: Q