

Recommended Land Pattern

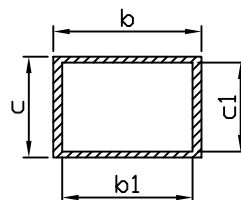

SECTION A-A

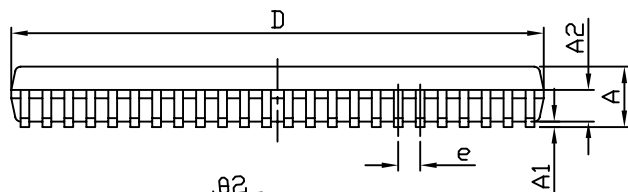
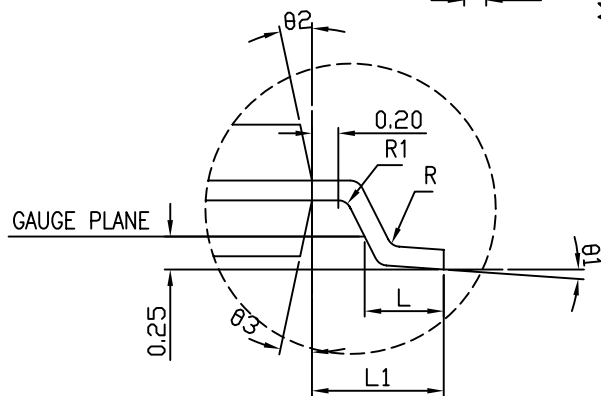

DETAIL A

SYMBOL	DIMENSION IN MM		
	MIN.	NOM.	MAX.
A			1.20
A1	0.05		0.15
A2	0.80	1.00	1.05
L	0.50	0.60	0.75
E	6.40 BSC.		
D	9.60	9.70	9.80
E1	4.30	4.40	4.50
R	0.09		
R1	0.09		
b	0.13		0.23
b1	0.13	0.16	0.19
c	0.09		0.20
c1	0.09		0.16
L1	1.0 REF.		
e	0.40 BSC.		
theta1	0		8
theta2	12 REF.		
theta3	12 REF.		

NOTE:

1. Refer JEDEC MO-153/CD
2. All dimensions are in mm. Angles in degrees.
3. Package outline dimensions exclude mold flash and metal burr.



DATE: 08/29/08

DESCRIPTION: 48-Pin, 173mil wide TVSOP (TSSOP)

PACKAGE CODE: K48

DOCUMENT CONTROL #: PD-1324

REVISION: D