

DOCUMENT CONTROL NO.
PD - 1902

REVISION: B
DATE: 03/09/05

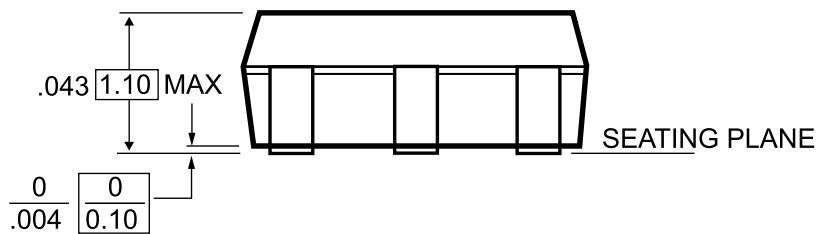
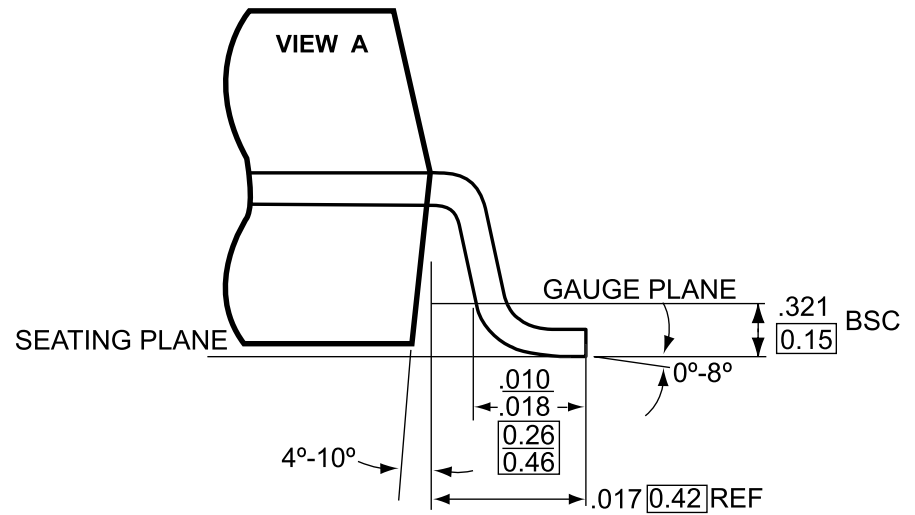
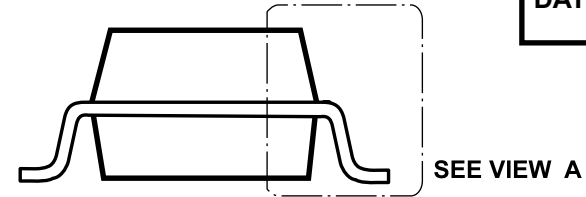
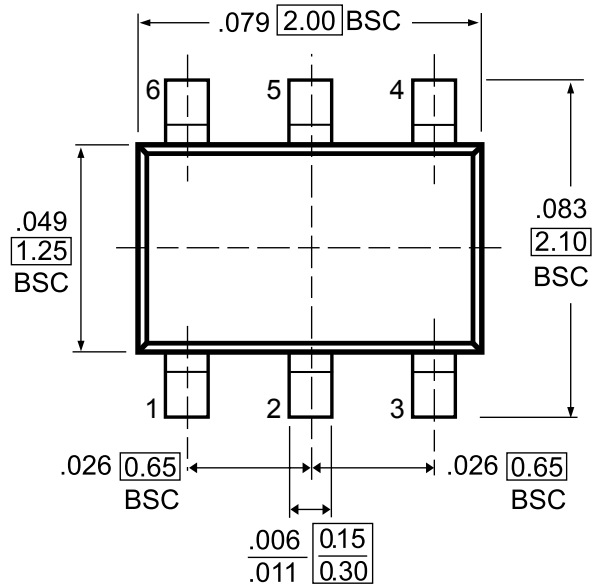

[XXX] DENOTES DIMENSIONS
[XXX] IN MILLIMETERS

Notes:

1. Controlling dimensions in millimeters
2. Ref: JEDEC MO-203B/AB
3. Package Outline Exclusive of Mold Flash and Metal Burr



Pericom Semiconductor Corporation
3545 N. 1st Street, San Jose, CA 95134
1-800-435-2335 • www.pericom.com

DESCRIPTION: 6-Pin, SC70

PACKAGE CODE: C