

DOCUMENT CONTROL NO.
PD - 1503

REVISION: B
DATE: 03/09/05

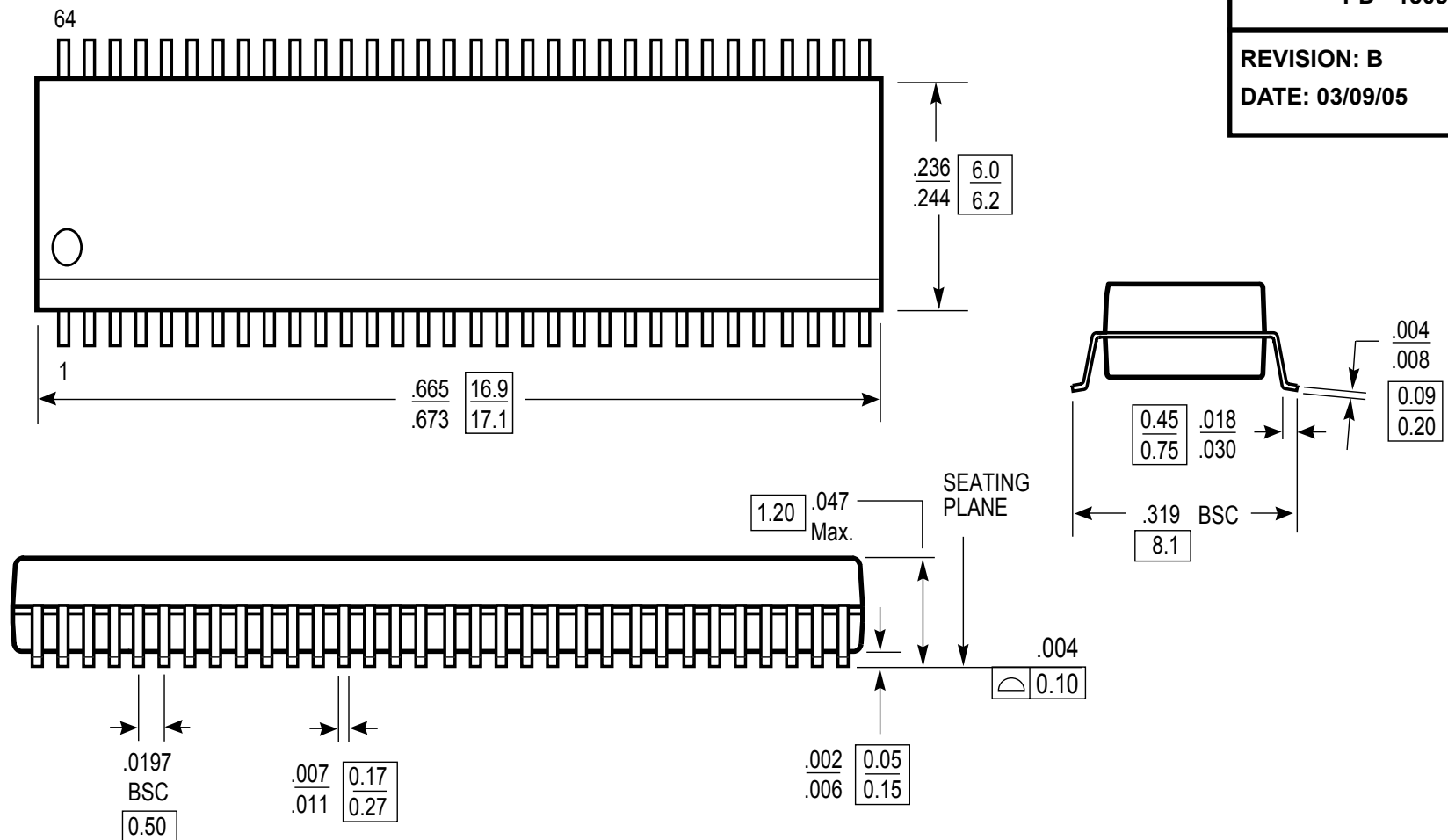

Notes:

1. Maximum package length and width dimensions do not include mold flash protrusions or gate burrs, which shall not exceed 0.006 inch per side
2. Controlling dimensions in millimeters.
3. Ref: JEDEC MO-153F/EF
4. Package Outline Exclusive of Mold Flash and Metal Burr



Pericom Semiconductor Corporation
3545 N. 1st Street, San Jose, CA 95134
1-800-435-2335 • www.pericom.com

DESCRIPTION: 64-Pin, 240-Mil Wide TSSOP

PACKAGE CODE: A