

Technical Data

PrO™ S8002 Ceramic Series

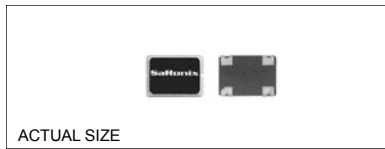

Description

Acrytal controlled, HCMOS compatible oscillator with an internal programming feature that allows SaRonix to supply most frequencies in the 1 to 90MHz range. This technology significantly reduces lead-times from weeks to days. The parts exhibit the same low power, precise rise and fall times, tight symmetry and HCMOS drive capability as conventional SaRonix SMD oscillators. The parts feature tri-state enable or standby control on pad 1. The packages are miniature ceramic SMD, measuring 5 x 7 x 1.8 mm.

Applications & Features

- Quick delivery of any frequency between 1 and 90MHz.
- Suited for use with new HCMOS MPUs and DSPs.
- Tri-State output or standby mode
- High Drive HCMOS capability
- Stabilities of ± 25 , ± 50 , ± 100 ppm
- 5.0V version is available, see separate data sheet
- Available on tape & reel; 16mm tape, 500pcs per reel
- See S16xx series for low jitter performance

Frequency Range:	1MHz to 90MHz
Frequency Stability:	$\pm 25^{**}$, ± 50 or ± 100 ppm over all conditions: calibration tolerance, operating temperature, rated input (supply) voltage change, load change, *aging, shock and vibration.
*Aging:	30 days
** ± 25 ppm not available for all frequencies	
Temperature Range:	
Operating:	-20 to +70°C or -40 to +85°C
Storage:	-55 to +125°C
Supply Voltage:	
Recommended Operating:	3.3V $\pm 10\%$ or 3.0V $\pm 10\%$ (+7V absolute max)
Supply Current:	
	25mA (1 to 40 MHz)
	35mA (40+ to 90 MHz)
	50 μ A max (applicable to low-power stand-by mode only when specified)
Output Drive:	
Symmetry:	45/55% measured @ 50% V _{DD} (1 to 40 MHz, -20 to +70°C, 3.3V only) 40/60% measured @ 50% V _{DD} (all other conditions)
Rise & Fall Times:	5ns max 20% to 80% V _{DD}
Logic 0:	0.4V max
Logic 1:	V _{DD} -0.4V min
Load:	30pF max 1 to 40MHz, 15pF max 40+ to 90MHz @ 3.3V 15pF max 1 to 40MHz @ 3.0V
Period Jitter RMS:	25ps typ, 50ps max 33+ to 90 MHz 33ps typ, 100ps max 5+ to 33 MHz 117ps typ, 167ps max 1 to 5 MHz
Output Enable (Tri-state Control) Function:	
Output Oscillation:	$(70\% V_{DD}) \leq V_{IN} \leq (V_{DD} + 0.5V)$, or N/C
Output High Impedance:	$(-0.5V) \leq V_{IN} \leq (30\% V_{DD})$, or GND
Disable High Delay:	≤ 100 ns
Internal Pullup Resistance:	$\geq 15k\Omega$
Low-Power Stand-by Function:	
Output Oscillation:	$(70\% V_{DD}) \leq V_{IN} \leq (V_{DD} + 0.5V)$, or N/C
Stand-by Mode:	$(-0.5V) \leq V_{IN} \leq (30\% V_{DD})$, or GND
Control Input Current:	$\leq 10\mu$ A
Mechanical:	
Shock:	MIL-STD-883, Method 2002, Condition B
Solderability:	MIL-STD-883, Method 2003
Terminal Strength:	MIL-STD-883, Method 2004, Condition D
Vibration:	MIL-STD-883, Method 2007, Condition A
Solvent Resistance:	MIL-STD-202, Method 215
Resistance to Soldering Heat:	MIL-STD-202, Method 210, Condition I or J
Environmental:	
Thermal Shock:	MIL-STD-883C, Method 1011, Condition A
Moisture Resistance:	MIL-STD-883C, Method 1004

Technical Data

PrOTM S8002 Ceramic Series

Package Details

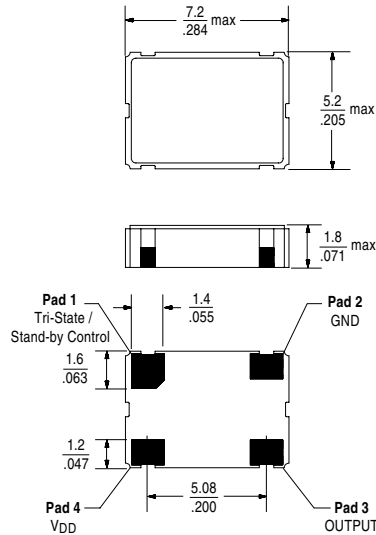

Marking Format (Exact location of items may vary)

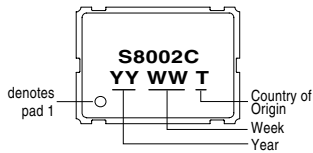

*Exact location of items may vary

Recommended Land Pattern

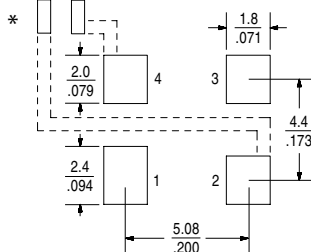

* External high frequency power supply decoupling required.

Scale: None (Dimensions in mm / inches)

Part Numbering Guide

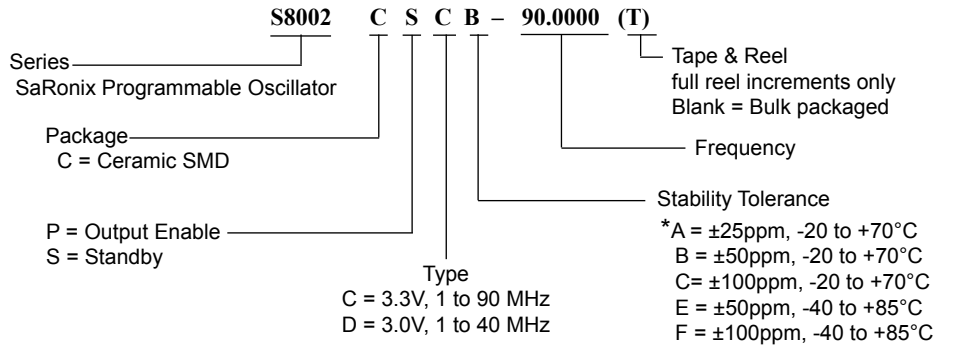

*Please contact SaRonix for available frequencies @ ±25ppm.

Output Waveform

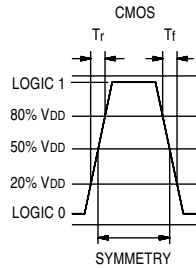

Solder Reflow Guide

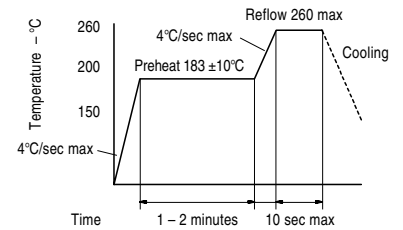

Test Circuits

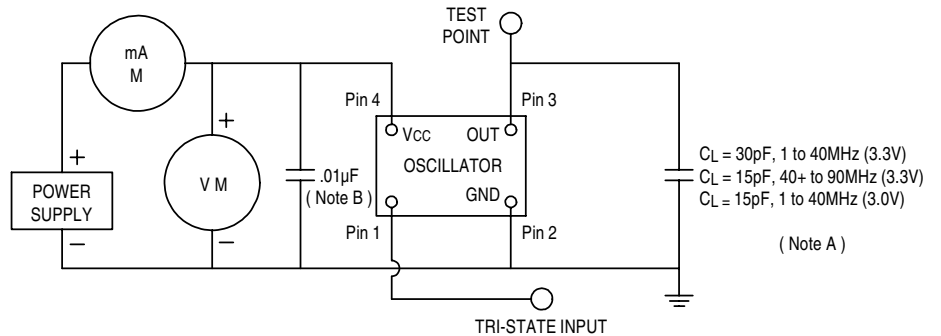

NOTE: A. CL includes probe and fixture capacitance.
NOTE: B. An external .01µF bypass capacitor close to package ground and VCC pin is required

HCMOS (Used at SaRonix)

All specifications subject to changes without notice