

PCIe 2.0 Clock Generator with 2 HCSL Outputs

Features

- PCIe® 2.0 compliant
 - Phase jitter - 2.1ps RMS (typ)
- LVDS compatible outputs
- Supply voltage of 3.3V ±10%
- 25MHz crystal or clock input frequency
- HCSL outputs, 0.8V Current mode differential pair
- Jitter 35ps cycle-to-cycle (typ)
- Spread of -0.5%, -0.75%, and no spread
- Industrial temperature range
- Spread Bypass option available
- Spread and frequency selection via external pins
- Packaging: (Pb-free and Green)
 - 16-pin TSSOP (L16)
 - 16-pin QSOP (Q16)

Description

The PI6C557-03A is a spread spectrum clock generator compliant to PCI Express® 2.0 and Ethernet requirements. The device is used for PC or embedded systems to substantially reduce Electro-magnetic Interference (EMI).

The PI6C557-03A provides two differential (HCSL) or LVDS spread spectrum outputs. The PI6C557-03A is configured to select spread and clock selection. Using Pericom's patented Phase-Locked Loop (PLL) techniques, the device takes a 25MHz crystal input and produces two pairs of differential outputs (HCSL) at 25MHz, 100MHz, 125MHz and 200MHz clock frequencies. It also provides spread selection of -0.5%, -0.75%, and no spread.

Block Diagram

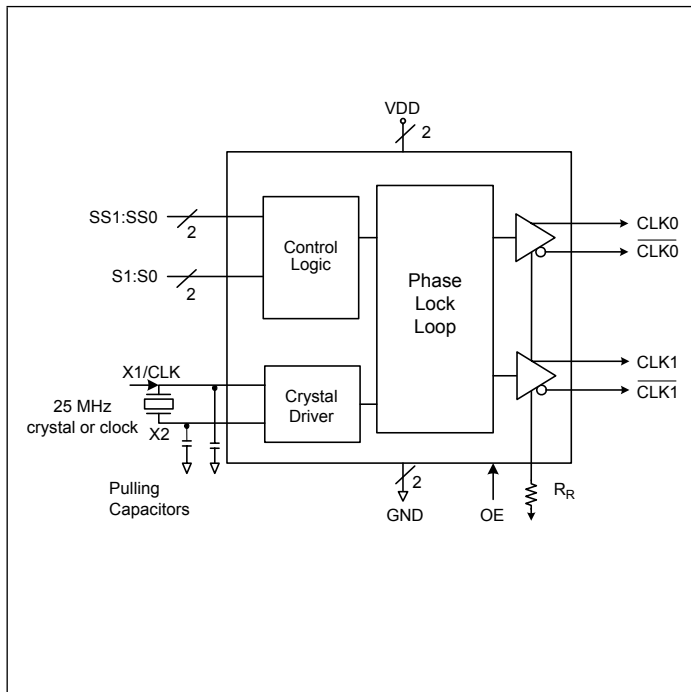

Pin Configuration (16-Pin TSSOP)

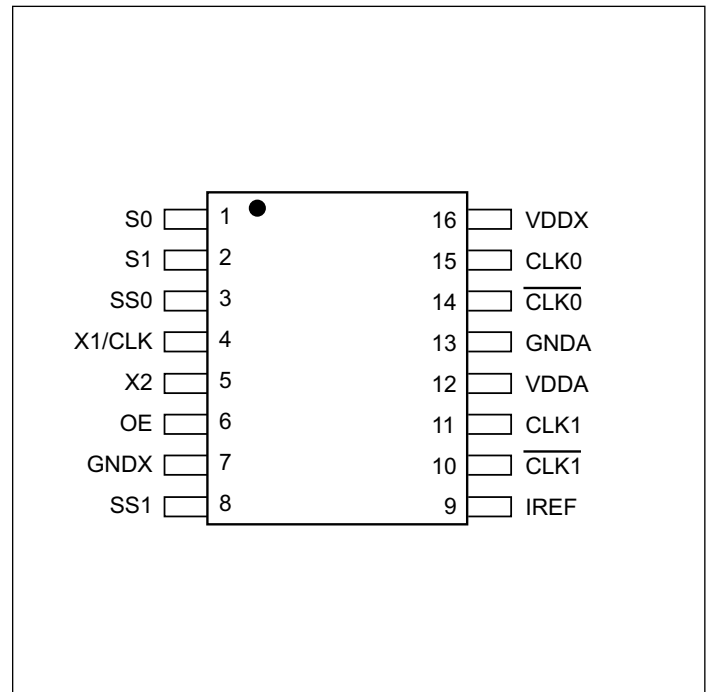

Pin Description

Pin #	Pin Name	I/O Type	Description
1	S0	Input	Select pin 0 (Internal pull-up resistor). See Table 1.
2	S1	Input	Select pin 1 (Internal pull-up resistor). See Table 1.
3	SS0	Input	Spread Select pin 0 (Internal pull-up resistor). See Table 2.
4	X1/CLK	Input	Crystal or clock input. Connect to a 25MHz crystal or single ended clock.
5	X2	Output	Crystal connection. Leave unconnected for clock input.
6	OE	Input	Output enable. Internal pull-up resistor.
7	GNDX	Power	Crystal ground pin.
8	SS1	Input	Spread Select pin 1 (Internal pull-up resistor). See Table 2.
9	IREF	Output	Precision resistor attached to this pin is connected to the internal current reference.
10	$\overline{\text{CLK1}}$	Output	HCSL compliment clock output
11	CLK1	Output	HCSL clock output
12	VDDA	Power	Connect to a +3.3V source.
13	GND A	Power	Output and analog circuit ground.
14	$\overline{\text{CLK0}}$	Output	HCSL compliment clock output
15	CLK0	Output	HCSL clock output
16	VDDX	Power	Connect to a +3.3V source.

Table 1: Output Select Table

S1	S0	CLK(MHz)
0	0	25
0	1	100
1	0	125
1	1	200

Table 2: Spread Selection Table

SS1	SS0	Spread
0	0	No Spread
0	1	Down -0.5
1	0	Down -0.75
1	1	No Spread

Application Information

Decoupling Capacitors

Decoupling capacitors of $0.01\mu\text{F}$ should be connected between each V_{DD} pin and the ground plane and placed as close to the V_{DD} pin as possible.

Crystal

Use a 25MHz fundamental mode parallel resonant crystal with less than 300PPM of error across temperature.

Crystal Capacitors

C_L = Crystals's load capacitance in pF

Crystal Capacitors (pF) = $(C_L - 8) * 2$

For example, for a crystal with 16pF load caps, the external effective crystal cap would be 16 pF. $(16-8)*2=16$.

Current Source (IREF) Reference Resistor - R_R

If board target trace impedance is 50Ω , then $R_R = 475\Omega$ providing an IREF of 2.32 mA. The output current (I_{OH}) is $6*IREF$.

Output Termination

The PCI Express differential clock outputs of the PI6C557-03A are open source drivers and require an external series resistor and a resistor to ground. These resistor values and their allowable locations are shown in detail in the PCI Express Layout Guidelines section.

The PI6C557-03A can be configured for LVDS compatible voltage levels. See the LVDS Compatible Layout Guidelines section.

Output Structures

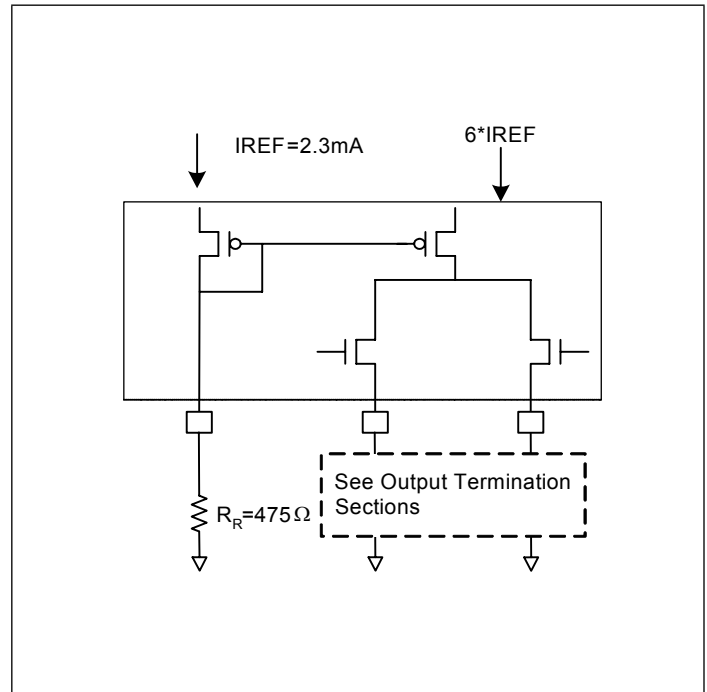

PCI Express Layout Guidelines

Common Recommendations for Differential Routing	Dimension or Value	Unit
L1 length, route as non-coupled 50Ω trace.	0.5 max	inch
L2 length, route as non-coupled 50Ω trace.	0.2 max	inch
L3 length, route as non-coupled 50Ω trace.	0.2 max	inch
R _S	33	Ω
R _T	49.9	Ω

Differential Routing on a Single PCB	Dimension or Value	Unit
L4 length, route as coupled microstrip 100Ω differential trace.	2 min to 16 max	inch
L4 length, route as coupled stripline 100Ω differential trace.	1.8 min to 14.4 max	inch

Differential Routing to a PCI Express connector	Dimension or Value	Unit
L4 length, route as coupled microstrip 100Ω differential trace.	0.25 min to 14 max	inch
L4 length, route as coupled stripline 100Ω differential trace.	0.225 min to 12.6 max	inch

PCI Express Device Routing

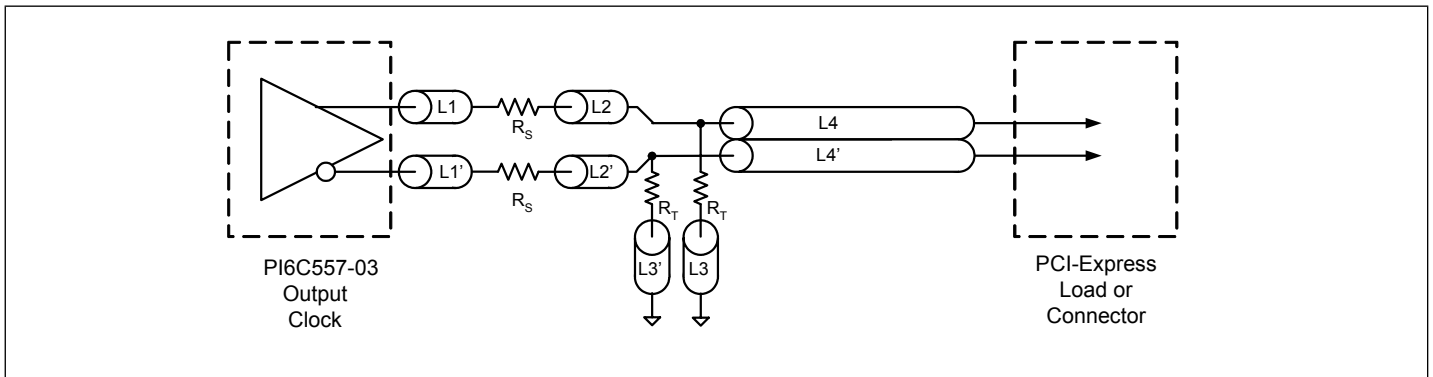

Typical PCI Express (HCSL) Waveform

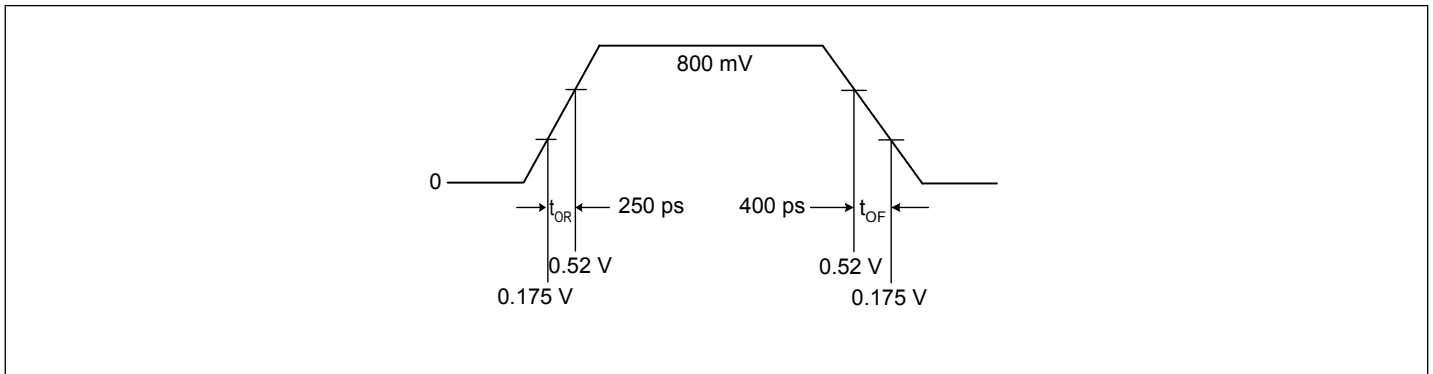

Application Information

LVDS Recommendations for Differential Routing	Dimension or Value	Unit
L1 length, route as non-coupled 50Ω trace.	0.5 max	inch
L2 length, route as non-coupled 50Ω trace.	0.2 max	inch
RP	100	Ω
RQ	100	Ω
RT	150	Ω
L3 length, route as 100Ω differential trace.		
L3 length, route as 100Ω differential trace.		

LVDS Device Routing

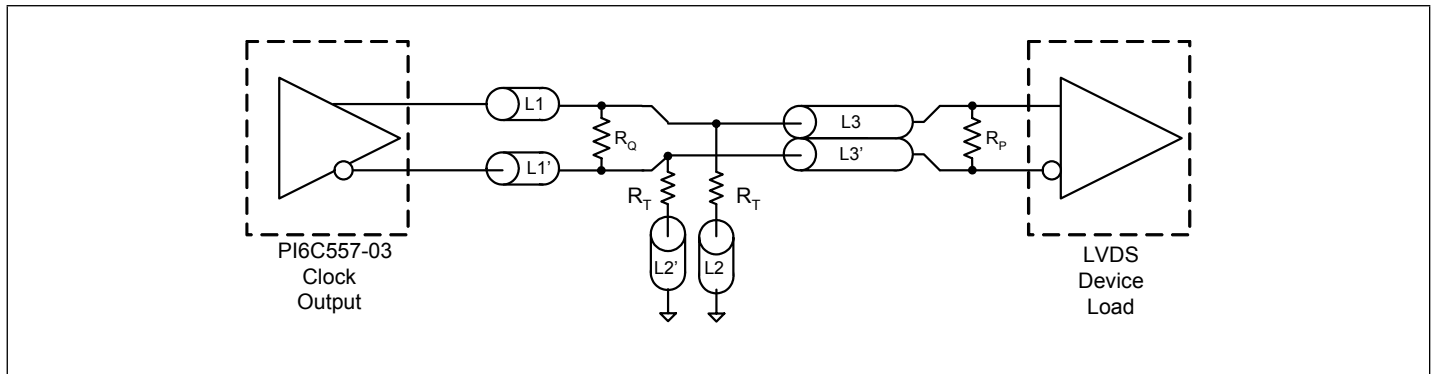

Maximum Ratings

(Above which useful life may be impaired. For user guidelines, not tested.)

Supply Voltage to Ground Potential	5.5V
All Inputs and Outputs	-0.5V to $V_{DD}+0.5V$
Ambient Operating Temperature	-40 to +85°C
Storage Temperature	-65 to +150°C
Junction Temperature	150°C
Soldering Temperature	260°C
EDS Protection (Input)	2000 V min (HBM)

Note:

Stresses greater than those listed under MAXIMUM RATINGS may cause permanent damage to the device. This is a stress rating only and functional operation of the device at these or any other conditions above those indicated in the operational sections of this specification is not implied. Exposure to absolute maximum rating conditions for extended periods may affect reliability.

Electrical Specifications

Recommended Operation Conditions

Parameter	Min.	Typ.	Max.	Unit
Ambient Operating Temperature	-40		+85	°C
Power Supply Voltage (measured in respect to GND)	+3.0		+3.6	V

DC Characteristics ($V_{DD} = 3.3V \pm 10\%$, $T_A = -40^\circ C$ to $+85^\circ C$)

Symbol	Parameter	Conditions	Min.	Typ.	Max.	Unit
V_{DD}	Supply Voltage		3.0	3.3	3.6	V
V_{IH}	Input High Voltage ⁽¹⁾	OE	2.0		$V_{DD} + 0.3$	V
V_{IL}	Input Low Voltage ⁽¹⁾	OE	GND - 0.3		0.8	V
I_{IL}	Input Leakage Current	$0 < V_{in} < V_{DD}$	With input pull-up and pull-downs	-20	20	μA
			Without input pull-up and pull-downs	-5	5	
I_{DD}	Operating Supply Current	$R_L = 50\Omega$, $C_L = 2pF$			95	mA
I_{DDOE}		OE = LOW			50	mA
C_{IN}	Input Capacitance	@ 55MHz			7	pF
C_{OUT}	Output Capacitance	@ 55MHz			6	pF
L_{PIN}	Pin Inductance				5	nH
R_{OUT}	Output Resistance	CLK Outputs	3.0			k Ω

Notes:

1. Single edge is monotonic when transitioning through region.

HCSL Output AC Characteristics ($V_{DD} = 3.3V \pm 10\%$, $T_A = -40^{\circ}C$ to $+85^{\circ}C$)

Symbol	Parameter	Conditions	Min.	Typ.	Max.	Unit
F_{IN}	Input Frequency			25		MHz
V_{OUT}	Output Frequency		25		200	MHz
V_{OH}	Output High Voltage ^(1,2)	100 MHz HCSL output @ $V_{DD} = 3.3V$	660	800	900	mV
V_{OL}	Output Low Voltage ^(1,2)		-150	0		mV
V_{CPA}	Crossing Point Voltage ^(1,2)	Absolute	250	350	550	mV
V_{CN}	Crossing Point Voltage ^(1,2,4)	Variation over all edges			140	mV
J_{CC}	Jitter, Cycle-to-Cycle ^(1,3)			35	60	ps
J_{RMS}	PCIe RMS Jitter	PCIe 2.0 Test Method @ 100MHz Output			3.1	ps
MF	Modulation Frequency	Spread Spectrum	30	31.5	33	kHz
t_{OR}	Rise Time ^(1,2)	From 0.175V to 0.525V	175		500	ps
t_{OF}	Fall Time ^(1,2)	From 0.525V to 0.175V	175		500	ps
T_{SKEW}	Skew between outputs	At Crossing Point Voltage			50	ps
$T_{DUTY-CYCLE}$	Duty Cycle ^(1,3)		45		55	%
T_{OE}	Output Enable Time ⁽⁵⁾	All outputs			10	μs
T_{OT}	Output Disable Time ⁽⁵⁾	All outputs			10	μs
t_{STABLE}	From power-up to $V_{DD}=3.3V$	From Power-up $V_{DD}=3.3V$		3.0		ms
t_{SPREAD}	Setting period after spread change	Setting period after spread change		3.0		ms

Notes:

1. $R_L = 50\text{-}\Omega$ with $C_L = 2\text{ pF}$
2. Single-ended waveform
3. Differential waveform
4. Measured at the crossing point
5. CLK pins are tri-stated when OE is LOW

Thermal Characteristics

Symbol	Parameter	Conditions	Min.	Typ.	Max.	Unit
θ_{JA}	Thermal Resistance Junction to Ambient	Still air			90	$^{\circ}C/W$
θ_{JC}	Thermal Resistance Junction to Case				24	$^{\circ}C/W$

Recommended Crystal Specification

Pericom recommends:

- a) GC2500003 XTAL 49S/SMD(4.0 mm), 25M, $CL=18\text{pF}$, $\pm 30\text{ppm}$
http://www.pericom.com/pdf/datasheets/se/GC_GE.pdf
- b) FY2500081, SMD 5x3.2(4P), 25M, $CL=18\text{pF}$, $\pm 30\text{ppm}$
http://www.pericom.com/pdf/datasheets/se/FY_F9.pdf
- c) FL2500047, SMD 3.2x2.5(4P), 25M, $CL=18\text{pF}$, $\pm 20\text{ppm}$
<http://www.pericom.com/pdf/datasheets/se/FL.pdf>

Packaging Mechanical: 16-Pin TSSOP (L)

DOCUMENT CONTROL NO. PD - 1310
REVISION: E DATE: 03/09/05

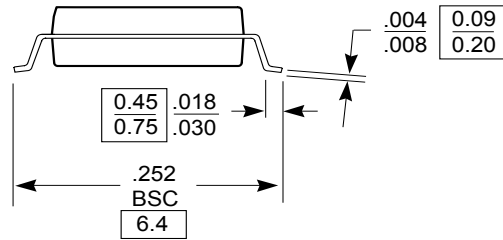
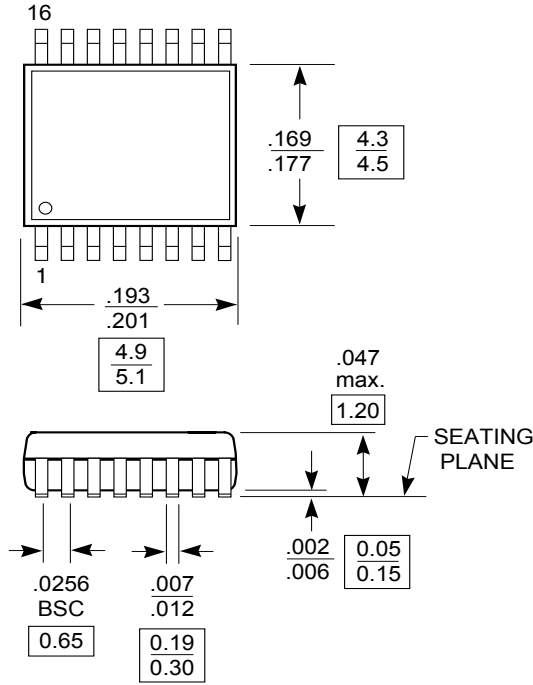

- Note:**
1. Package Outline Exclusive of Mold Flash and Metal Burr
 2. Controlling dimensions in millimeters
 3. Ref. JEDEC MO-153F/AB



Pericom Semiconductor Corporation
3545 N. 1st Street, San Jose, CA 95134
1-800-435-2335 • www.pericom.com

DESCRIPTION: 16-Pin, 173-Mil Wide, TSSOP

PACKAGE CODE: L

Note: For latest package info, please check: <http://www.pericom.com/products/packaging/mechanicals.php>

Packaging Mechanical: 16-Pin QSOP (Q)

<p style="text-align: center;">X.XX DENOTES DIMENSIONS IN MILLIMETERS X.XX</p> <p>Note: 1) Controlling dimensions in inches. 2) Ref: JEDEC MO-137B/AB. 3) Dimensions do not include mold flash, protrusions or gate burrs</p>	<p>DOCUMENT CONTROL NO. PD - 1201</p> <hr/> <p>REVISION: G</p> <p>DATE: 11/07/07</p>
<p>Pericom Semiconductor Corporation 3545 N. 1st Street, San Jose, CA 95134 1-800-435-2335 • www.pericom.com</p>	
<p>DESCRIPTION: 16-Pin 150-Mil Wide QSOP</p> <hr/> <p>PACKAGE CODE: Q</p>	

Note: For latest package info, please check: <http://www.pericom.com/products/packaging/mechanicals.php>

Ordering Information

Ordering Code	Package Code	Package Type
PI6C557-03ALE	L	Pb-free & Green, 16-pin TSSOP
PI6C557-03AQE	Q	Pb-free & Green, 16-pin QSOP

Notes:

- Thermal characteristics can be found on the company web site at www.pericom.com/packaging/
- "E" denotes Pb-free and Green
- Adding an "X" at the end of the ordering code denotes tape and reel packaging