

Features

- 14.318 MHz Crystal Input
- Selectable of 100, 133, 166, 200, 266, 333, and 400MHz CPU Output Frequencies
- SMBus: Power Management Control
- Spread Spectrum support (-0.5% down spread)
- Packaging (Pb-free & Green available):
- 56-Pin TSSOP (A)

Output Features

- Five Pairs of Differential CPU Clocks
- Four Pairs of SRC Clocks
- Seven PCI Clocks
- One 48 MHz USB clock
- Two REF clocks

Description

PI6C410B-01 is a high-speed, low-noise clock generator designed to work with Intel Server PCI-Express Chipset. Spread Spectrum PLL based clock generator reduce EMI emission and support a wide range of frequencies.

Jitter Performance

- < 85ps Cycle-to-Cycle CPU clock jitter
- < 350ps Cycle-to-Cycle 48 MHz clock jitter
- < 500ps Cycle-to-Cycle PCI clock jitter
- < 125ps Cycle-to-Cycle SRC clock jitter
- < 1000ps Cycle-to-Cycle REF clock jitter

Skew Performance

- < 100ps Output to output CPU clock skew
- < 500ps Output to output PCI clock skew
- < 250ps Output to output SRC clock skew

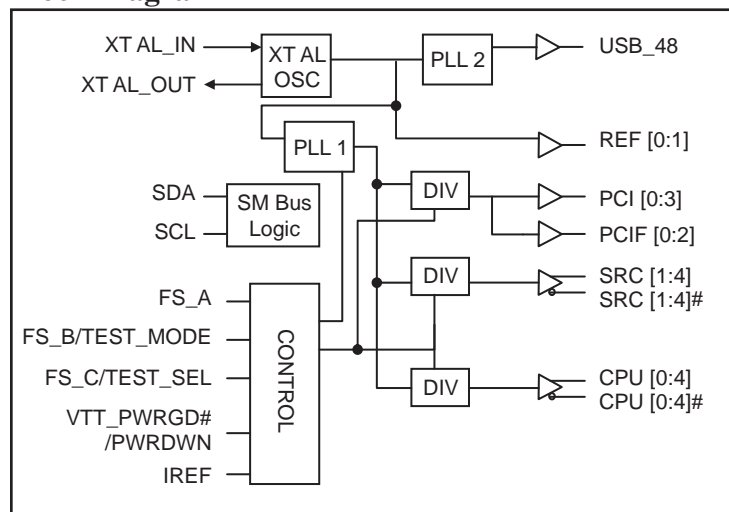
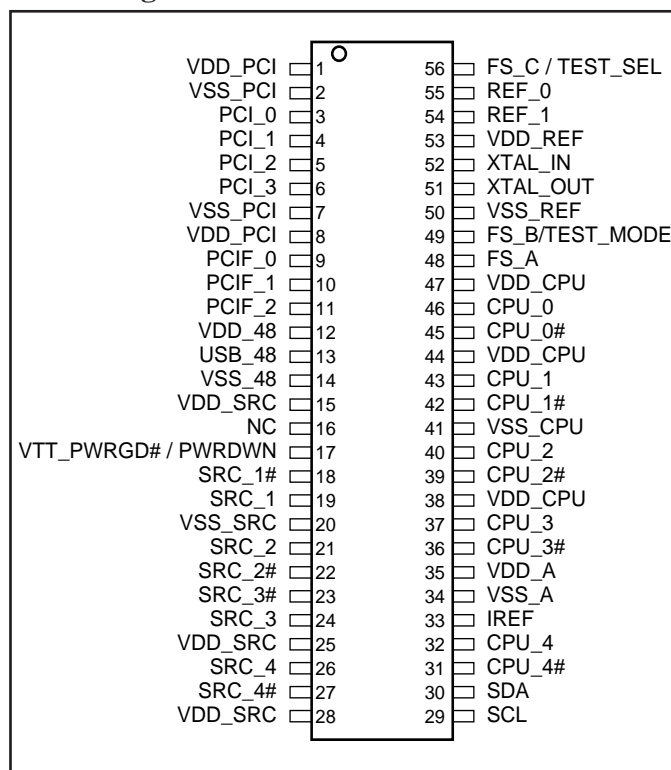
Block Diagram

Pin Configuration

Pin Descriptions

Pin Name	Type	Pin Number	Description
REF[0:1]	Output	54, 55	3.3V 14.31818 MHz outputs
XTAL_IN	Input	52	14.31818 MHz crystal input
XTAL_OUT	Output	51	14.31818 MHz crystal output
CPU[0:4] & CPU[0:4]#	Output	46,45, 43,42, 40,39, 37,36, 32,31	Differential CPU outputs
SRC[1:4] & SRC[1:4]#	Output	19,18; 21,22, 24,23, 26,27	Differential Serial Reference Clock outputs
PCIF[0:2]	Output	9, 10, 11	33 MHz clocks outputs (free running)
PCI[0:3]	Output	3, 4, 5, 6	33 MHz clocks outputs
USB_48	Output	13	48 MHz clock output
FS_A	Input	48	3.3V LVTTL inputs for CPU frequency selection
FS_B / TEST_MODE	Input	49	3.3V LVTTL inputs for CPU frequency selection / Test Mode select: 1 = Hi-Z, 0 = Ref/N
FS_C / TEST_SEL	Input	56	3.3V LVTTL inputs for CPU frequency selection / Test Mode select if pulled to 3.3V when Vtt_Pwrgd# is asserted LOW
IREF	Input	33	External resistor connection for internal current reference
VTT_PWRGD# / PWRDWN	Input	17	3.3V LVTTL Level sensitive strobe used to determine to latch the FS_A, FS_B/TEST_MODE, FS_C/TEST_SEL inputs (active low) / 3.3V LVTTL active high input for Power Down operation.
SDA	I/O	30	SMBus compatible SDATA
SCL	Input	29	SMBus compatible SCLOCK
VDD_PCI	Power	1, 8	3.3V Power Supply for Outputs
VDD_48	Power	12	3.3V Power Supply for Outputs
VDD_SRC	Power	15, 25, 28	3.3V Power Supply for Outputs
VDD_CPU	Power	38, 44, 47	3.3V Power Supply for Outputs
VDD_REF	Power	53	3.3V Power Supply for Outputs
VSS_PCI	Ground	2, 7	Ground for Outputs
VSS_48	Ground	14	Ground for Outputs
VSS_SRC	Ground	20	Ground for Outputs
VSS_CPU	Ground	41	Ground for Outputs
VSS_REF	Ground	50	Ground for Outputs
VDD_A	Power	35	3.3V Power Supply for PLL
VSS_A	Ground	34	Ground for PLL

Functionality

Frequency Selection

FS_C	FS_B	FS_A	CPU	SRC	PCIF / PCI	REF	USB_48	Note
1	0	1	100MHz	100MHz	33MHz	14.318MHz	48MHz	1
0	0	1	133MHz	100MHz	33MHz	14.318MHz	48MHz	1
0	1	1	166MHz	100MHz	33MHz	14.318MHz	48MHz	1
0	1	0	200MHz	100MHz	33MHz	14.318MHz	48MHz	1
0	0	0	266MHz	100MHz	33MHz	14.318MHz	48MHz	1
1	0	0	333MHz	100MHz	33MHz	14.318MHz	48MHz	1
1	1	0	400MHz	100MHz	33MHz	14.318MHz	48MHz	1
1	1	1	Reserved	100MHz	33MHz	14.318MHz	48MHz	1

Note:

1. Refer to DC Electrical Characteristics for FS_A, FS_B and FS_C (Vih_FS, Vil_FS) threshold levels

Test Mode Selection

TEST MODE	CPU	SRC	PCIF / PCI	REF	USB 48	Note
1	REF/N	REF/N	REF/N	REF	REF/N	2
0	Hi-Z	Hi-Z	Hi-Z	Hi-Z	Hi-Z	2

Note:

2. Test mode will occur where the SMBus Bit 6 of Byte 6 = 1, or FS_C/TEST_SEL is set to logic high level.

PWRDWN Functionality

PWRDWN	CPU	CPU#	SRC	SRC#	PCIF / PCI	REF	USB 48
0	Normal	Normal	Normal	Normal	33MHz	14.318MHz	48MHz
1	Iref × 2 or Float	Float	Iref × 2 or Float	Float	Low	Low	Low

Serial Data Interface (SMBus)

The PI6C410B-01 is a slave only SMBus device that supports both indexed block read and indexed block write protocol using a single 7-bit address and read/write bit as shown below.

Address Assignment

A6	A5	A4	A3	A2	A1	A0	R/W
1	1	0	1	0	0	1	0/1

Data Protocol⁽³⁾

1 bit	7 bits	1	1	8 bits	1	8 bits	1	8 bits	1		8 bits	1	1 bit
Start bit	Slave Addr	R/W	Ack	Register offset	Ack	Byte Count = N	Ack	Data Byte 0	Ack	...	Data Byte N - 1	Ack	Stop bit

Note:

- Register offset for indicating the starting register for indexed block write and indexed block read. Byte Count in write mode cannot be 0.

Data Byte 0: Control Register

Bit	Descriptions	Type	Power Up Condition	Output	Pin	Source Pin
0	CPU_4 Output Enable 1 = Enabled, 0 = Disabled (Hi-Z)	RW	1 = Enabled	CPU_4, CPU_4#	32, 31	NA
1	SRC_1 Output Enable 1 = Enabled, 0 = Disabled (Hi-Z)	RW	1 = Enabled	SRC_1	19, 18	NA
2	SRC_2 Output Enable 1 = Enabled, 0 = Disabled (Hi-Z)	RW	1 = Enabled	SRC_2	21, 22	NA
3	SRC_3 Output Enable 1 = Enabled, 0 = Disabled (Hi-Z)	RW	1 = Enabled	SRC_3	24, 23	NA
4	SRC_4 Output Enable 1 = Enabled, 0 = Disabled (Hi-Z)	RW	1 = Enabled	SRC_4	26, 27	NA
5	Reserved	RW				
6	Reserved	RW				
7	Reserved	RW				

Data Byte 1: Control Register

Bit	Descriptions	Type	Power Up Condition	Output	Pin	Source Pin
0	Spread Spectrum 1 = On, 0 = Off	RW	0 = Spread off	CPU[0:3], SRC[1:4], PCI[0:3], PCIF[0:2]	3, 4, 5, 6, 9, 10, 11, 18, 19, 21, 22, 23, 24, 26, 27, 31, 32, 36, 37, 39, 40, 42, 43, 45, 46	NA
1	CPU_0 Output Enable 1 = Enabled, 0 = Disabled (Hi-Z)	RW	1 = Enabled	CPU_0, CPU_0#	45, 46	NA
2	CPU_1 Output Enable 1 = Enabled, 0 = Disabled (Hi-Z)	RW	1 = Enabled	CPU_1, CPU_1#	42, 43	NA
3	Reserved	RW				
4	CPU_2 Output Enable 1 = Enabled, 0 = Disabled (Hi-Z)	RW	1 = Enabled	CPU_2, CPU_2#	39, 40	NA
5	CPU_3 Output Enable 1 = Enabled, 0 = Disabled (Hi-Z)	RW	1 = Enabled	CPU_3, CPU_3#	36, 37	NA
6	REF0 Output Enable 1 = Enabled, 0 = Disabled	RW	1 = Enabled	REF_0	55	NA
7	REF1 Output Enable 1 = Enabled, 0 = Disabled	RW	1 = Enabled	REF_1	54	NA

Data Byte 2: Control Register

Bit	Descriptions	Type	Power Up Condition	Output	Pin	Source Pin
0	USB_48 Output Enable 1 = Enabled, 0 = Disabled	RW	1 = Enabled	USB_48	13	NA
1	PCIF_0 Output Enable 1 = Enabled, 0 = Disabled	RW	1 = Enabled	PCIF_0	9	NA
2	PCIF_1 Output Enable 1 = Enabled, 0 = Disabled	RW	1 = Enabled	PCIF_1	10	NA
3	PCIF_2 Output Enable 1 = Enabled, 0 = Disabled	RW	1 = Enabled	PCIF_2	11	NA
4	PCI_0 Output Enable 1 = Enabled, 0 = Disabled	RW	1 = Enabled	PCI_0	3	NA
5	PCI_1 Output Enable 1 = Enabled, 0 = Disabled	RW	1 = Enabled	PCI_1	4	NA
6	PCI_2 Output Enable 1 = Enabled, 0 = Disabled	RW	1 = Enabled	PCI_2	5	NA
7	PCI_3 Output Enable 1 = Enabled, 0 = Disabled	RW	1 = Enabled	PCI_3	6	NA

Data Byte 3: Control Register

Bit	Descriptions	Type	Power Up Condition	Output	Pin	Source Pin
0	CPU_4 Output Control 0 = Free Running 1 = Stopped with CPU_STOP#	RW	Stopped with 1 = CPU_STOP# Assertion	CPU_4, CPU_4#	32, 31	NA
1	SRC_1 Output Control 0 = Free Running 1 = Stopped with PCI_STOP#	RW	0 = Free running	SRC_1, SRC_1#	18, 19	NA
2	SRC_2 Output Control 0 = Free Running 1 = Stopped with PCI_STOP#	RW	0 = Free running	SRC_2, SRC_2#	21, 22	NA
3	SRC_3 Output Control 0 = Free Running 1 = Stopped with PCI_STOP#	RW	0 = Free running	SRC_3, SRC_3#	23, 24	NA
4	SRC_4 Output Control 0 = Free Running 1 = Stopped with PCI_STOP#	RW	0 = Free running	SRC_4, SRC_4#	26, 27	NA
5	PCIF0 Output Control 0 = Free Running 1 = Stopped with PCI_STOP#	RW	0 = Free running	PCIF_0	9	NA
6	PCIF1 Output Control 0 = Free Running 1 = Stopped with PCI_STOP#	RW	0 = Free running	PCIF_1	10	NA
7	PCIF2 Output Control 0 = Free Running 1 = Stopped with PCI_STOP#	RW	0 = Free running	PCIF_2	11	NA

Data Byte 4: Control Register

Bit	Descriptions	Type	Power Up Condition	Output	Pin	Source Pin
0	CPU_0 Output Control 0 = Free Running 1 = Stopped with CPU_STOP#	RW	1 = Stopped with CPU_STOP# assertion	CPU_0, CPU0#	45, 46	NA
1	CPU_1 Output Control 0 = Free Running 1 = Stopped with CPU_STOP#	RW	1 = Stopped with CPU_STOP# assertion	CPU_1, CPU1#	42, 43	NA
2	CPU_2 Output Control 0 = Free Running 1 = Stopped with CPU_STOP#	RW	1 = Stopped with CPU_STOP# assertion	CPU_2, CPU2#	39, 40	NA
3	CPU_3 Output Control 0 = Free Running 1 = Stopped with CPU_STOP#	RW	1 = Stopped with CPU_STOP# assertion	CPU_3, CPU3#	36, 37	NA
4	CPU_0 Pwrdsn drive mode 1 = Hi-Z, 0 = Driven in Pwrdsn	RW	0 = Driven in power down	CPU_0, CPU0#	45, 46	NA
5	CPU_1 Pwrdsn drive mode 1 = Hi-Z, 0 = Driven in Pwrdsn	RW	0 = Driven in power down	CPU_1, CPU1#	42, 43	NA
6	CPU_2 Pwrdsn drive mode 1 = Hi-Z, 0 = Driven in Pwrdsn	RW	0 = Driven in power down	CPU_2, CPU2#	39, 40	NA
7	CPU_3 Pwrdsn drive mode 1 = Hi-Z, 0 = Driven in Pwrdsn	RW	0 = Driven in power down	CPU_3, CPU3#	36, 37	NA

Data Byte 5: Control Register

Bit	Descriptions	Type	Power Up Condition	Output	Pin	Source Pin
0	CPU_0 CPU_Stop drive mode 1 = Hi-Z, 0 = Driven in CPU Stop	RW	0 = Driven in CPU_Stop	CPU_0, CPU0#	45, 46	NA
1	CPU_1 CPU_Stop drive mode 1 = Hi-Z, 0 = Driven in CPU Stop	RW	0 = Driven in CPU_Stop	CPU_1, CPU1#	42, 43	NA
2	CPU_2 CPU_Stop drive mode 1 = Hi-Z, 0 = Driven in CPU Stop	RW	0 = Driven in CPU_Stop	CPU_2, CPU2#	39, 40	NA
3	CPU_3 CPU_Stop drive mode 1 = Hi-Z, 0 = Driven in CPU Stop	RW	0 = Driven in CPU_Stop	CPU_3, CPU3#	36, 37	NA
4	CPU_4 CPU_Stop drive mode 1 = Hi-Z, 0 = Driven in CPU Stop	RW	0 = Driven in CPU_Stop	CPU_4, CPU4#	32, 31	NA
5	SRC_Pwrdsn drive mode 1 = Hi-Z, 0 = Driven in Pwrdsn	RW	0 = Driven in power down	SRC[0:4] & SRC[0:4]#	16, 17, 18, 19, 21, 22, 23, 24, 26, 27	NA
6	SRC_Stop drive mode 1 = Hi-Z, 0 = Driven in PCI_STOP	RW	0 = Driven in PCI_STOP	SRC[0:4] & SRC[0:4]#	16, 17, 18, 19, 21, 22, 23, 24, 26, 27	NA
7	CPU_4 Pwrdsn drive mode 1 = Hi-Z, 0 = Driven in CPU Stop	RW	0 = Driven in Pwrdsn	CPU_4, CPU4#	32, 31	NA

Data Byte 6: Control Register

Bit	Descriptions	Type	Power Up Condition	Output	Pin	Source Pin
0	FS_A Reflects the value of the FS_A pin sampled on power up 0 = FS_A was low during Vtt_Pwrgd# assertion	R	Externally Selected	CPU[0:4]	36, 37, 39, 40, 42, 43, 45, 46, 31, 32	NA
1	FS_B Reflects the value of the FS_B pin sampled on power up 0 = FS_B was low during Vtt_Pwrgd# assertion	R	Externally Selected	CPU[0:3]	36, 37, 39, 40, 42, 43, 45, 46	NA
2	FS_C Reflects the value of the FS_C pin sampled on power up 0 = FS_C was low during Vtt_Pwrgd# assertion	R	Externally Selected	CPU[0:3]	36, 37, 39, 40, 42, 43, 45, 46	NA
3	PCI_Stop Output Control 0 = Enabled, all stoppable PCI and SRC clocks are stopped, 1 = Disabled	RW	1 = Disabled	All PCI & SRC clocks except PCIF and SRC clocks set to free-running	3, 4, 5, 6, 18, 19, 21, 22, 23, 24, 26, 27	NA
4	REF Output Drive Strength 0 = 1X, 1 = 2X	RW	1 = 2X	REF_0, REF_1	54, 55	NA
5	CPU_Stop# Control 0 = Stop non-free running PC and SRC clocks, 1 = Run	RW	Run			NA
6	Test Clock Mode Entry Control 0 = Normal, 1 = REF/N or Hi-Z	RW	0 = Disabled			NA
7	Test Clock Mode 0 = Hi-Z, 1 = REF/N	RW	0 = Hi-Z			NA

Data Byte 7: Pericom ID Register

Bit	Descriptions	Type	Power Up Condition	Output	Pin
0	Vendor ID	R	0	NA	NA
1		R	0	NA	NA
2		R	0	NA	NA
3		R	0	NA	NA
4	Revision Code	R	0	NA	NA
5		R	0	NA	NA
6		R	0	NA	NA
7		R	0	NA	NA

Data Byte 8: Block Read Byte Count

Bit	Descriptions	Type	Power Up Condition	Output	Pin
0	Block Read Byte Count	R	0	NA	NA
1	Block Read Byte Count	R	1	NA	NA
2	Block Read Byte Count	R	1	NA	NA
3	Block Read Byte Count	R	1	NA	NA
4	Block Read Byte Count	R	0	NA	NA
5	Block Read Byte Count	R	0	NA	NA
6	Block Read Byte Count	R	0	NA	NA
7	Block Read Byte Count	R	0	NA	NA

Power Down (PWRDWN assertion)

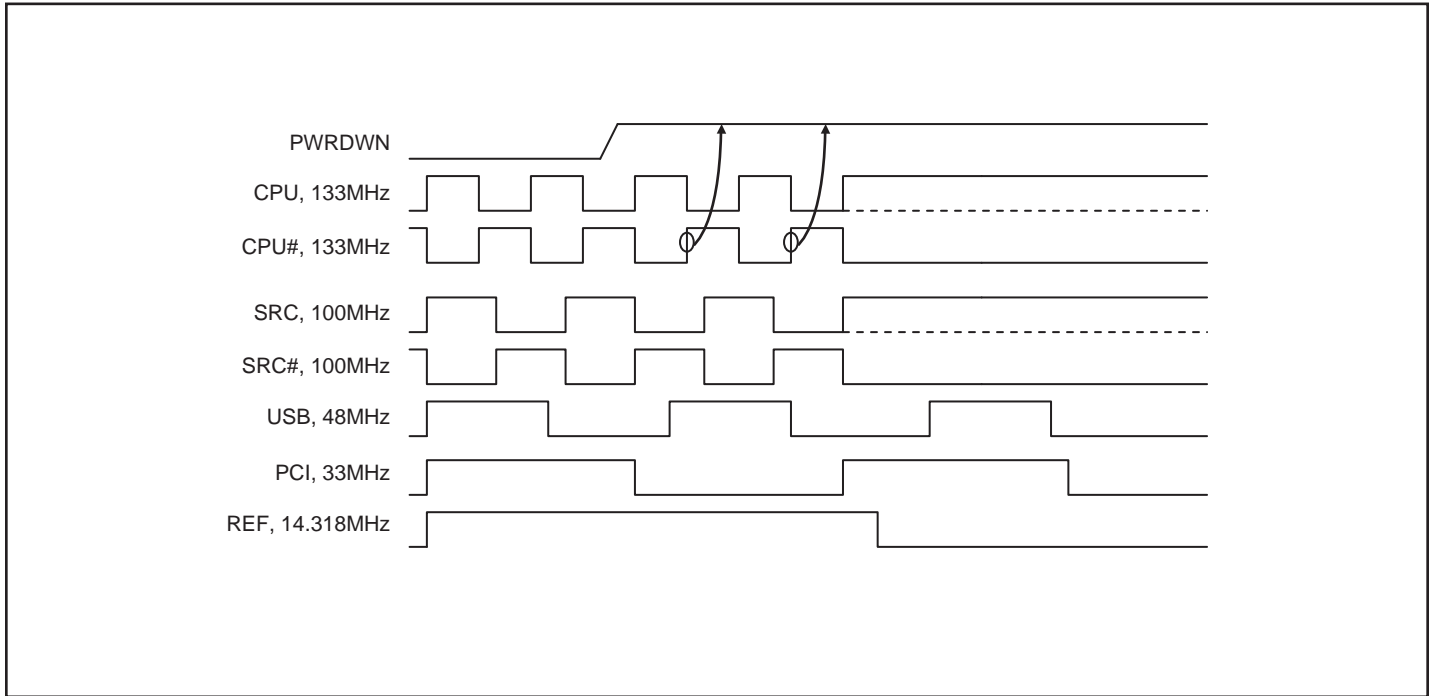

Figure 1. Power down sequence

Power Down (PWRDWN De-assertion)

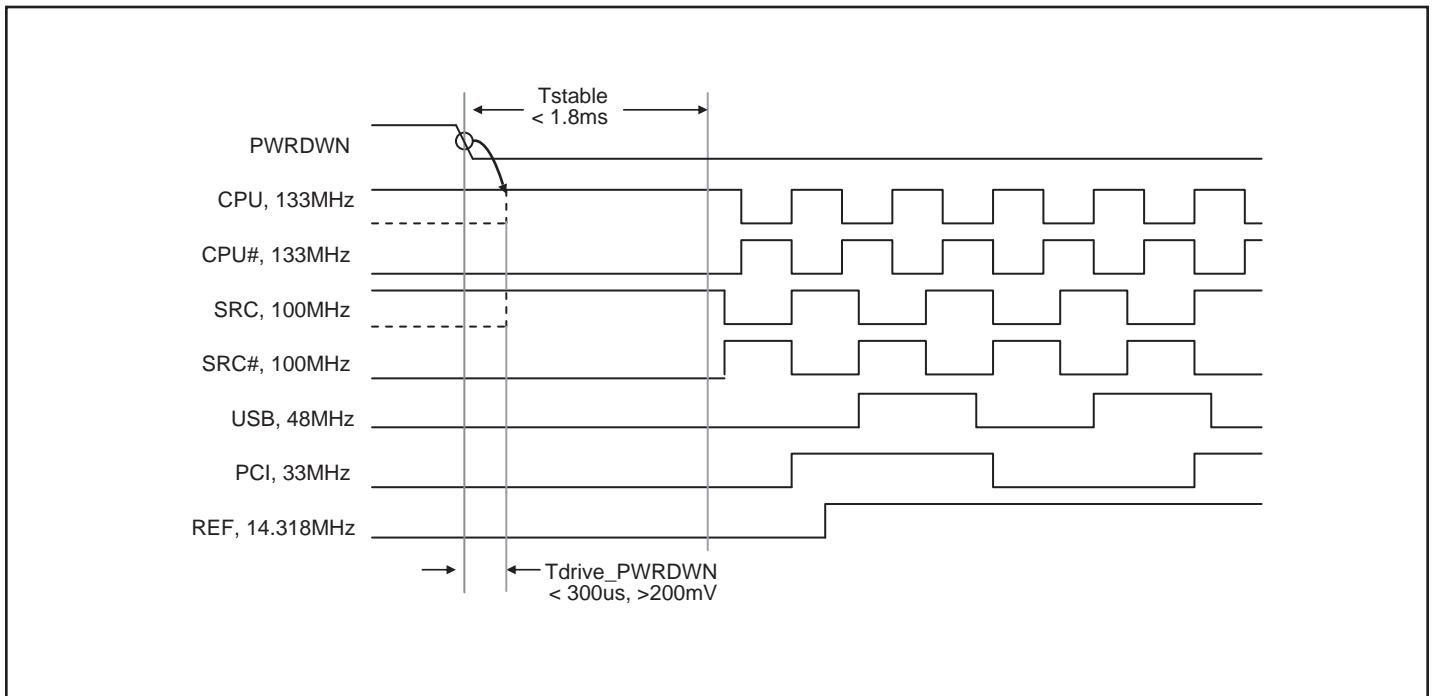

Figure 2. Power down de-assert sequence

Tristate Specifications

CPU & SRC Tristate clock truth table

Signal	Pwrdsn pin	Pwrdsn Tristate Bit	Stoppable Outputs	Non-stop Outputs
CPU[0:3], SRC[0:4],	0	X	Running	Running
	1	0	Driven @ Iref x 2	Driven @ Iref x 2
	1	1	Tristate	Tristate

Spread Spectrum Specifications

The PI6C410B supports Spread Spectrum clocks and can be enabled and disabled via SMBus control. The maximum Spread Spectrum Modulation is -0.5% down spread with frequency from 30KHz to 33KHz.

SSC ON	Tperiod		SSC OFF	Tperiod		Unit
	Min	Max		Min	Max	
CPU @ 399.000MHz	2.4993	2.5133	CPU @ 400.000MHz	2.4993	2.5008	ns
CPU @ 332.500MHz	2.9991	3.0160	CPU @ 333.333MHz	2.9991	3.0009	
CPU @ 266.000MHz	3.7489	3.7700	CPU @ 266.666MHz	3.7489	3.7511	
CPU @ 199.500MHz	4.9985	5.0266	CPU @ 200.000MHz	4.9985	5.0015	
CPU @ 166.250MHz	5.9982	6.0320	CPU @ 166.666MHz	5.9982	6.0018	
CPU @ 133.000MHz	7.4978	7.5400	CPU @ 133.333MHz	7.4978	7.5023	
CPU @ 99.750MHz	9.9970	10.0533	CPU @ 100.000MHz	9.9970	10.0030	
SRC @ 99.750MHz	9.9970	10.0533	SRC @ 100.000MHz	9.9970	10.0030	
PCIF / PCI @ 33.250MHz	29.9910	30.1598	PCIF / PCI @ 33.333MHz	29.9910	30.0090	

Crystal Recommendations⁽⁴⁾

Frequency	Cut	Loading	Load Cap	Drive Max.	Shunt Cap Max.	Motional Cap Max.	Tolerance Max.	Stability Max.	Aging Max.
14.31818MHz	AT	Parallel	20pF	0.1mW	5pF	0.016pF	50ppm	50ppm	5ppm

Note:

4. External trim capacitors (Ce) are required by using this formula $C_e = 2 * C_L - (C_s + C_i)$. Typical Ce = 33pF when Crystal Load = 20pF, Trace capacitance (Cs) = 2.8pF and XTAL pins capacitance = 4.5pF.

Current-mode output buffer characteristics of CPU and SRC

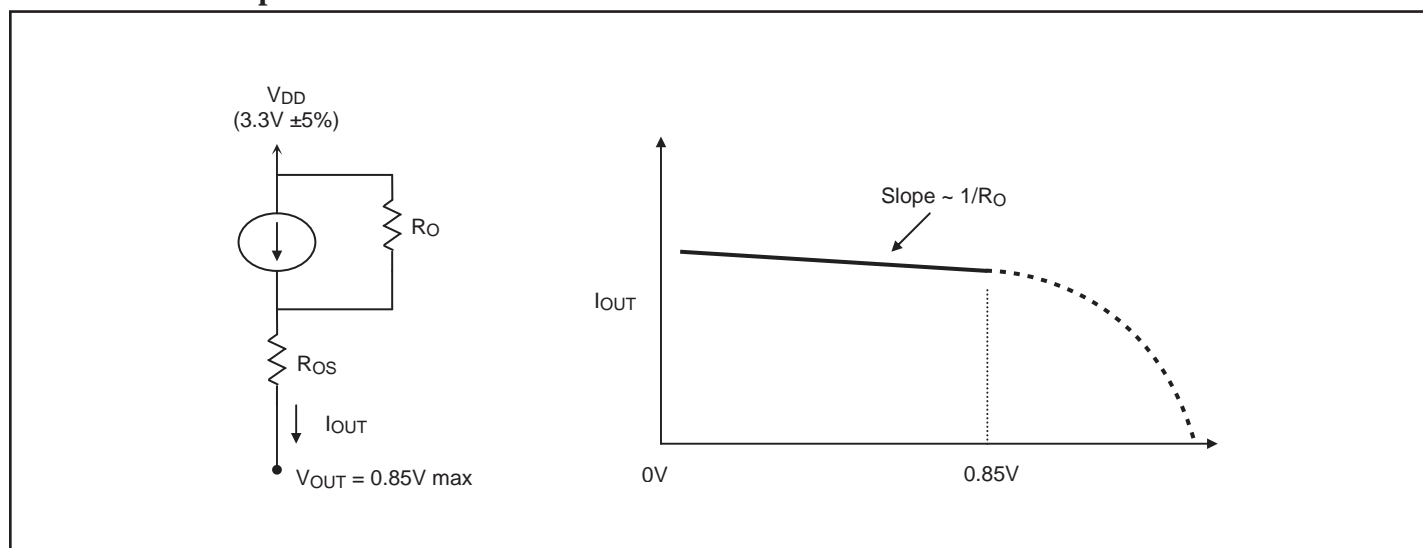

Figure 3. Simplified diagram of current-mode output buffer

Host Clock Buffer Characteristics

Symbol	Minimum	Maximum
R_O	3000Ω	N/A
R_{OS}	unspecified	unspecified
V_{OUT}	N/A	850mV

Current Accuracy⁽⁵⁾

Symbol	Conditions	Configuration	Load	Min.	Max.
I_{OUT}	$V_{DD} = 3.30 \pm 5\%$	$R_{REF} = 475\Omega$ 1% $I_{REF} = 2.32mA$	Nominal test load for given configuration	-12% $I_{NOMINAL}$	+12% $I_{NOMINAL}$

Note:

5. $I_{NOMINAL}$ refers to the expected current based on the configuration of the device.

Host Clock Output Current

Board Target Trace/Term Z	Reference R, $I_{REF} = V_{DD}/(3 \times R_r)$	Output Current	$V_{OH} @ Z$
100Ω (100Ω differential \approx 8% coupling ratio)	$R_{REF} = 475\Omega$ 1%, $I_{REF} = 2.32mA$	$I_{OH} = 6 \times I_{REF}$	0.7V @ 50

Absolute Maximum Ratings⁽¹⁾ (Over operating free-air temperature range)

Symbol	Parameters	Min.	Max.	Units
V _{DD_A}	3.3V Core Supply Voltage	-0.5	4.6	V
V _{DD}	3.3V I/O Supply Voltage	-0.5	4.6	
V _{IH}	Input High Voltage		4.6	
V _{IL}	Input Low Voltage	-0.5		
T _s	Storage Temperature	-65	150	°C
V _{ESD}	ESD Protection	2000		V

Note:

1. Stress beyond those listed under “Absolute Maximum Ratings” may cause permanent damage to the device.

DC Electrical Characteristics (V_{DD} = 3.3±5%, V_{DD_A} = 3.3±5%, T_A = 0 to 70°C)

Symbol	Parameters	Condition	Min.	Max.	Units	
V _{DD_A}	3.3V Core Supply Voltage		3.135	3.465	V	
V _{DD}	3.3V I/O Supply Voltage		3.135	3.465		
V _{IH}	3.3V Input High Voltage	V _{DD}	2.0	V _{DD} + 0.3		
V _{IL}	3.3V Input Low Voltage		V _{SS} - 0.3	0.8		
I _{IK}	Input Leakage Current	0 < V _{IN} < V _{DD}	-5	+5	µA	
V _{IH_FS}	3.3V Input High Voltage		0.7	V _{DD} + 0.3	V	
V _{IL_FS}	3.3V Input Low Voltage		V _{SS} - 0.3	0.35		
V _{OH}	3.3V Output High Voltage	I _{OH} = -1mA	2.4			
V _{OL}	3.3V Output Low Voltage	I _{OL} = 1mA		0.4		
I _{OH}	Output High Current	CPU, SRC: I _{OH} = 6 x I _{ref} , I _{ref} = 2.32mA	12.2	15.6	mA	
			USB	V _{OH} = 1.0V		-29
		V _{OH} = 3.135V				-23
		REF, PCI	V _{OH} = 1.0V	-33		
V _{OH} = 3.135V			-33			
I _{OL}	Output Low Current	USB	V _{OL} = 1.95V	29		
			V _{OL} = 0.4V			27
		REF, PCI	V _{OL} = 1.95V	30		
			V _{OL} = 0.4V		38	
C _{in}	Input Pin Capacitance		3	6	pF	
C _{xtal}	Xtal Pin Capacitance		3	6		
C _{out}	Output Pin Capacitance			6		
L _{pin}	Pin Inductance			7	nH	
I _{DD}	Power Supply Current	V _{DD} = 3.465V, F _{CPU} = 400MHz		500	mA	
I _{SS}	Power Down Current	Driven outputs		85		
I _{SS}	Power Down Current	Tristate outputs		12		

AC Switching Characteristics ($V_{DD} = 3.3 \pm 5\%$, $V_{DD_A} = 3.3 \pm 5\%$, $T_A = 0$ to 70°C)

Symbol	Outputs	Parameters	Min	Max.	Units	Notes	
$T_{\text{rise}} / T_{\text{fall}}$	CPU, SRC	Rise and Fall Time (measured between 0.175V to 0.525V)	175	700	ps	6, 7	
$T_{\text{rise}} / T_{\text{fall}}$	PCI/PCIF, REF	Rise and Fall Edge Rate (measured between 0.8V to 2.0V)	1	4	V/ns	9	
$T_{\text{rise}} / T_{\text{fall}}$	USB	Rise and Fall Edge Rate (measured between 0.8V to 2.0V)	1	2		9	
$\Delta T_{\text{rise}} / \Delta T_{\text{fall}}$	CPU, SRC	Rise and Fall Time Variation		125	ps	6, 7	
T_{skew}	CPU	CPU – CPU Skew (Measured at 3.3V at 266MHz)		115	ps	6, 8	
T_{skew}	SRC	SRC – SRC Skew		250		6, 8	
T_{skew}	PCI/PCIF, REF	PCI – PCI Skew / REF - REF Skew (measured at 1.5V)		500		9	
T_{jitter}	CPU	Cycle – Cycle Jitter		85		6, 8	
T_{jitter}	SRC	Cycle – Cycle Jitter		125		6, 8	
T_{jitter}	PCI/PCIF	Cycle – Cycle Jitter (measured at 1.5V)		500		9	
T_{jitter}	USB	Cycle – Cycle Jitter (measured at 1.5V)		350		9	
T_{jitter}	REF	Cycle – Cycle Jitter (measured at 1.5V)		1000		9	
V_{HIGH}	CPU, SRC	Voltage High including overshoot	660	1150		mV	6, 7
V_{LOW}	CPU, SRC	Voltage Low including undershoot	-300				6, 7
V_{CROSS}	CPU, SRC	Absolute crossing poing voltages	250	550	6, 7		
ΔV_{CROSS}	CPU, SRC	Total Variation of Vcross over all edges		140	6, 7		
T_{DC}	CPU, SRC	Duty Cycle	45	55	%	6, 8	
T_{DC}	REF, USB, PCI/PCIF	Duty Cycle (measured at 1.5V)	45	55		9	
T_{stable}		All clock stabilization from power-up		1.8	ms	Fig 2	
$T_{\text{drive Powerdown}}$		Differential output enable after Power Down de-assertion		300	μs	Fig 2	
$T_{\text{rise}} / T_{\text{fall Powerdown}}$		Power Down rise and fall time		5.0	ns		

Notes:

6. Test configuration: $R_s = 33.2\Omega$, $R_p = 49.9\Omega$, and 2pF.
7. Measurement taken from Single Ended waveform.
8. Measurement taken from Differential waveform.
9. $3.3V_{CC}$, one load for PCI/PCIF and USB with $R_s = 33\Omega \pm 5\%$. Three loads for Ref with $R_s = 12\Omega \pm 5\%$. Max length 20" into 5pF with 60 Ω impedance

Configuration test load board termination⁽¹⁰⁾

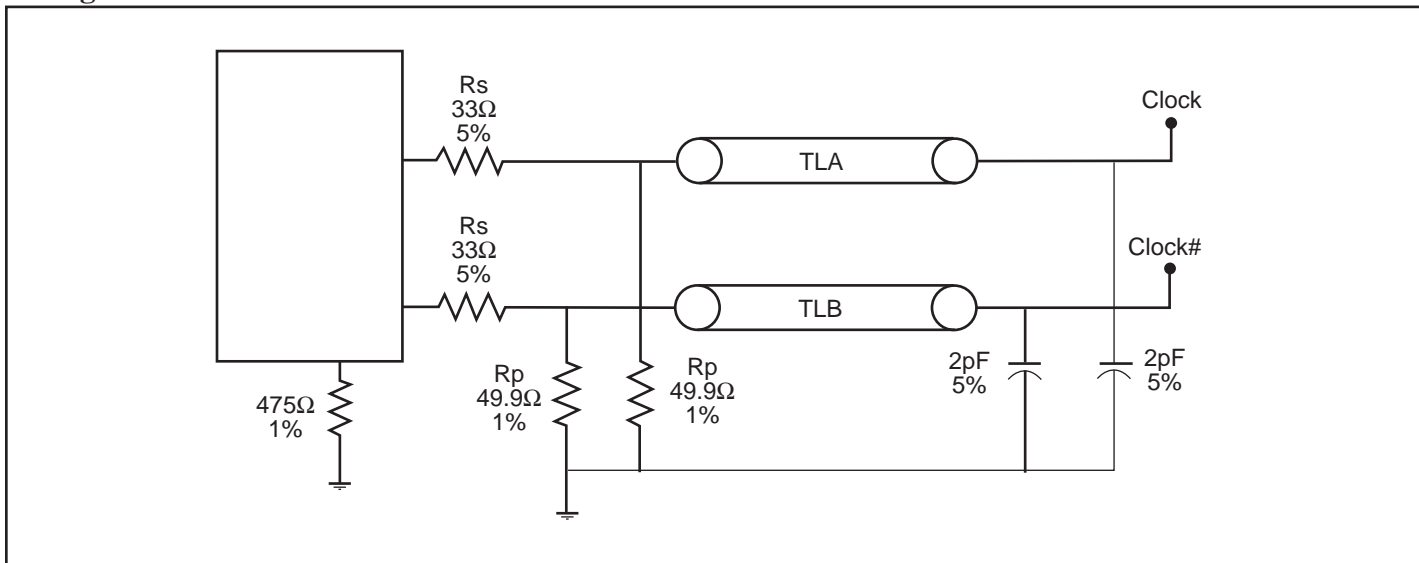
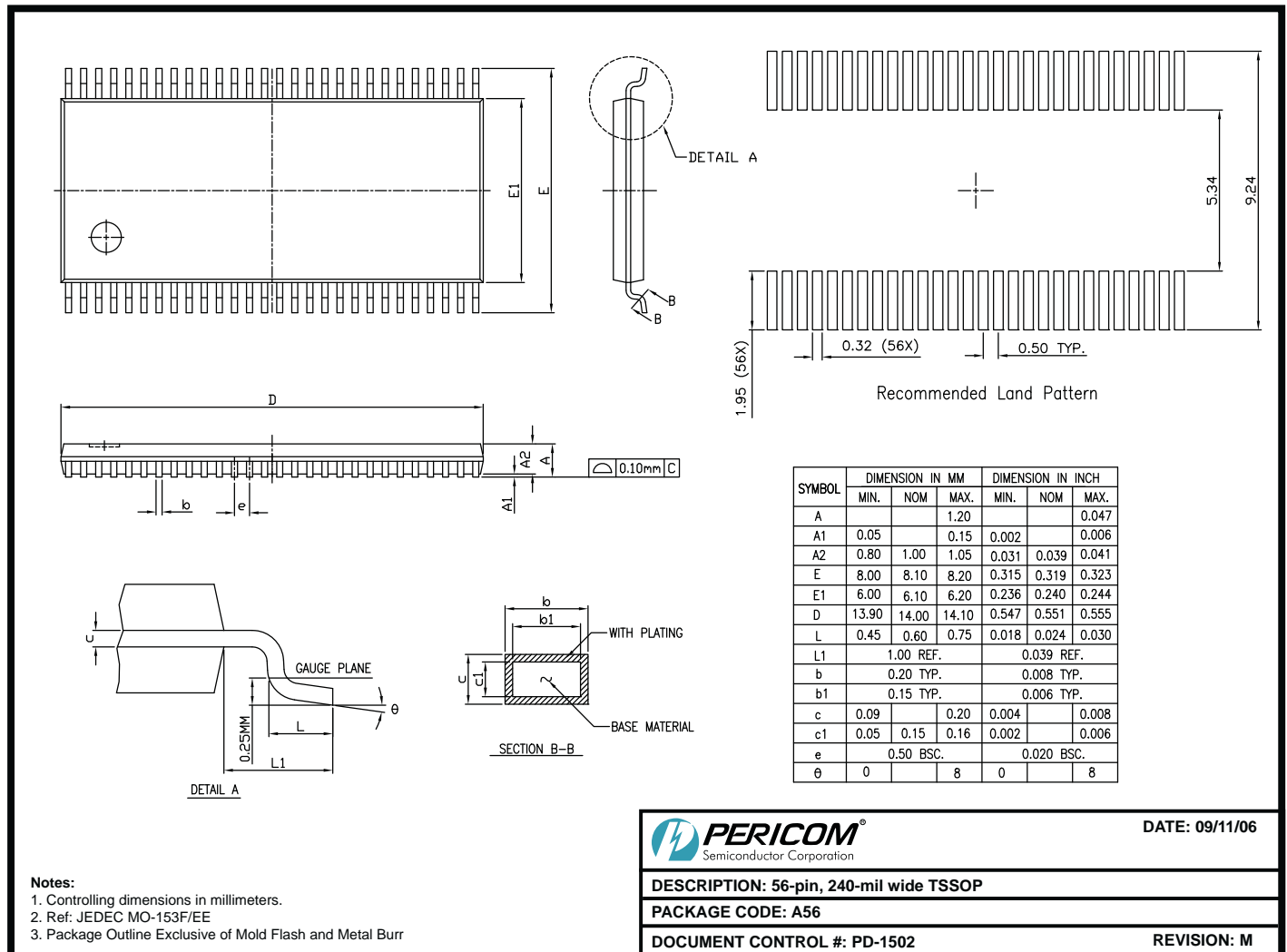

Figure 4. Configuration test load board termination

Note:

10. Maximum 10" trace length for CPU outputs at 200MHz. Maximum 16" trace length for SRC outputs at 100MHz.

Packaging Mechanical: 56-Pin, 240-mil wide TSSOP (A)



06-0736

Note:

- For latest package info, please check: <http://www.pericom.com/products/packaging/mechanicals.php>

Ordering Information⁽¹⁻³⁾

Ordering Code	Package Code	Package Description
PI6C410B-01AE	A	Pb-free & Green, 56-pin TSSOP

Notes:

- Thermal characteristics can be found on the company web site at www.pericom.com/packaging/
- E = Pb-free and Green
- X suffix = Tape/Reel