

**DLP Spread Spectrum Clock Synthesizer**
**Product Features**

- 3.3V operation voltage
- 27 MHz reference input
- Selectable CPU clock output with Spread Spectrum
- Selectable video clock output
- Synthesized error versus target 0 ppm
- 6-pin SOT-23 Package
- Commercial temperature 0°C to +70°C

**Description**

The PI6C3451 is a clock signal synthesizer with Spread Spectrum function to minimize EMI interference. By using a 27 MHz reference clock or crystal as input, the PI6C3451 generates a CPU clock and a video clock.

Spread Spectrum control is selectable through external logic state setting. The small SOT23 package outline can save board size and is easy for layout.

PI6C3451 is one of many Pericom clock products. If you have application needs with clock input or output not specified here, please contact Pericom for further information.

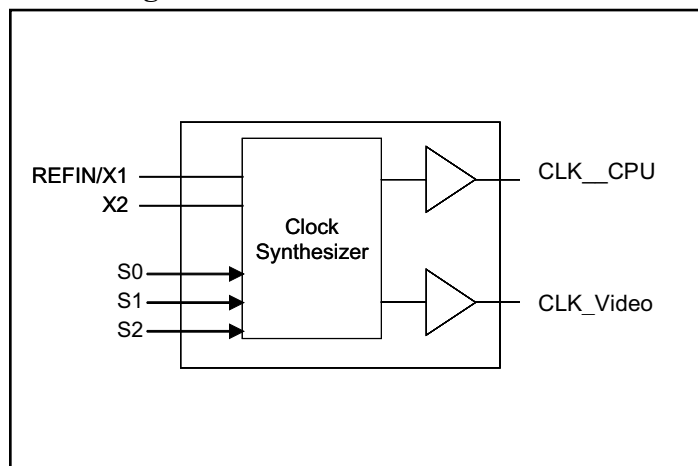
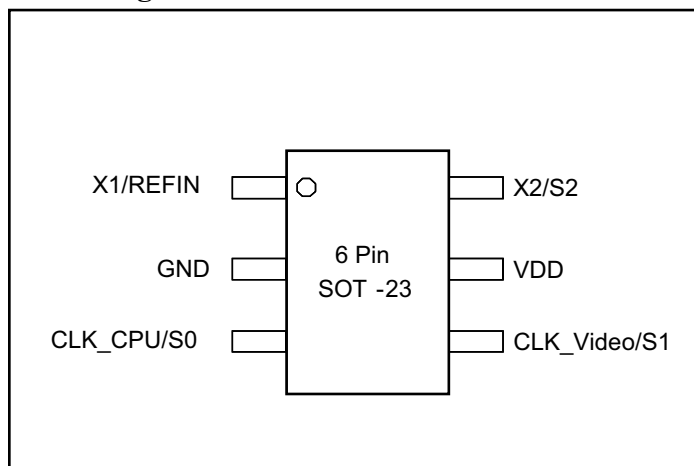
**Block Diagram**

**Pin Configuration**

**Pin Description**

| Pin Name     | Pin No | IO Type | Descriptions  |
|--------------|--------|---------|---|
| X1/REFIN     | 1      | I/O     | Crystal or reference clock input  |
| GND          | 2      | Ground  | Ground  |
| CLK_CPU/S0   | 3      | I/O     | S0 is activated during power on for logic state strapping and then switches to selected CPU clock output.                       |
| CLK_Video/S1 | 4      | I/O     | S1 is activated during power on for logic state strapping and then switches to selected video decoder clock output.             |
| VDD          | 5      | Power   | Power Supply  |
| X2/S2        | 6      | I/O     | X2/S2 is a multiple function pin. S2 is activated during power on for logic state strapping and then switches to crystal input. |

**Clock Control Selection Tables**

VDD = 3.3V ±10%, Ambient Temperature 0°C to +70°C

**CPU Clock Output Selection**

| CLK_CPU | S0 |
|---------|----|
| 50 MHz  | 0  |
| 100 MHz | 1  |

**Video Decoder Clock Output Selection**

| CLK_Video  | S1 |
|------------|----|
| 24.576 MHz | 0  |
| 48 MHz     | 1  |

**Spread Spectrum Ratio Selection for CPU Clock**

| S2 | Spread |
|----|--------|
| 0  | -0.5%  |
| 1  | -1%    |

## Electrical Specifications

### Maximum Ratings

|   |                                |
|---|--------------------------------|
| Supply Voltage to Ground Potential..... | 5.5V                           |
| All Inputs and Outputs.....             | -0.5V to V <sub>DD</sub> +0.5V |
| Storage Temperature .....               | -65°C to +150°C                |
| Junction Temperature .....              | 150°C                          |
| Soldering Temperature .....             | 260°C                          |

**Note:**

Stresses greater than those listed under MAXIMUM RATINGS may cause permanent damage to the device. This is a stress rating only and functional operation of the device at these or any other conditions above those indicated in the operational sections of this specification is not implied. Exposure to absolute maximum rating conditions for extended period may affect reliability.

### Recommended Operation Conditions

| Parameter                     | Min. | Typ. | Max. | Unit |
|-------------------------------|------|------|------|------|
| Ambient Operating Temperature | 0    |      | +70  | °C   |
| Power Supply Voltage          | +3.0 |      | +3.6 | V    |

### DC Characteristics (V<sub>DD</sub> = 3.3V ±10%, Ambient Temperature 0 to +70°C)

| Symbol                     | Parameter                                 | Conditions               | Min. | Typ. | Max. | Unit |   |
|----------------------------|---|--------------------------|------|------|------|------|---|
| V <sub>DD</sub>            | Operating Voltage                         |                          | 2.5  | 3.3  | 3.6  | V    |   |
| V <sub>IH</sub>            | Input High Voltage                        |                          | 2    |      |      |      |   |
| V <sub>IL</sub>            | Input Low Voltage                         |                          |      |      | 0.8  |      |   |
| V <sub>OH CPU</sub>        | Output High Voltage for CLK_CPU           | I <sub>OH</sub> = -14 mA | 2.4  |      |      |      |   |
| V <sub>OL CPU</sub>        | Output Low Voltage for CLK_CPU            | I <sub>OL</sub> = 14 mA  |      |      | 0.5  |      |   |
| V <sub>OH VIDEO</sub>      | Output High Voltage for CLK_VIDEO         | I <sub>OH</sub> = -7 mA  | 2.4  |      |      |      |   |
| V <sub>OL VIDEO</sub>      | Output Low Voltage for CLK_VIDEO          | I <sub>OL</sub> = 7 mA   |      |      | 0.5  | mA   |   |
| I <sub>DD</sub>            | Supply Current with all outputs activated | C <sub>L</sub> = 15pF    |      | 47   | 60   |      |   |
| Z <sub>OUT up CPU</sub>    | Nominal Output Impedance for CLK_CPU      | Up side buffer           |      | 22   |      |      | Ω |
| Z <sub>OUT low CPU</sub>   | Nominal Output impedance for CLK_CPU      | Low side buffer          |      | 22   |      |      |   |
| Z <sub>OUT up VIDEO</sub>  | Nominal Output Impedance for CLK_VIDEO    | Up side buffer           |      | 43   |      |      |   |
| Z <sub>OUT low VIDEO</sub> | Nominal Output impedance for CLK_VIDEO    | Low side buffer          |      | 43   |      |      |   |
| C <sub>in</sub>            | Input Capacitance                         | Input pins               |      | 5    |      | pF   |   |

**AC Characteristics** ( $V_{DD} = 3.3V \pm 10\%$ , Ambient Temperature  $0^{\circ}C$  to  $+70^{\circ}C$ )

| Symbol            | Parameter                                 | Conditions  | Min. | Typ. | Max. | Unit |
|-------------------|---|---|------|------|------|------|
| $f_{in}$          | REFIN Input Frequency                     |   |      | 27   |      | MHz  |
| $t_{Rise\_CPU}$   | Output Clock Rise Time for CLK_CPU        | 20% to 80% VDD, 15 pF load  |      | 1    |      | ns   |
| $t_{Fall\_CPU}$   | Output Clock Fall Time for CLK_CPU        | 80% to 20% VDD, 15 pF load  |      | 1.3  |      |      |
| $t_{Rise\_Video}$ | Output Clock Rise Time for CLK_Video      | 20% to 80% VDD, 15 pF load  |      | 2.2  |      |      |
| $t_{Fall\_Video}$ | Output Clock Fall Time for CLK_Video      | 80% to 20% VDD, 15 pF load  |      | 2.6  |      |      |
| $T_{dcin}$        | Input Clock Duty Cycle                    | REFIN/X1  | 20   | 50   | 80   | %    |
| $T_{dcout}$       | Output Clock Duty Cycle                   | Measured at $V_{DD}/2$  | 45   | 50   | 55   |      |
| $T_{j\_short}$    | Short term jitter                         | Cycle to cycle  |      | 250  | 350  | ps   |
| $\Delta f/f$      | Actual mean frequency error versus target | Input frequency = 27 MHz<br>Output frequency = CLK_CPU or CLK_Video |      | 0    |      | ppm  |

**Note:** Typical conditions are at 3.3V for room temperature  $25^{\circ}C$ .

## Application Information

### Reference Circuits

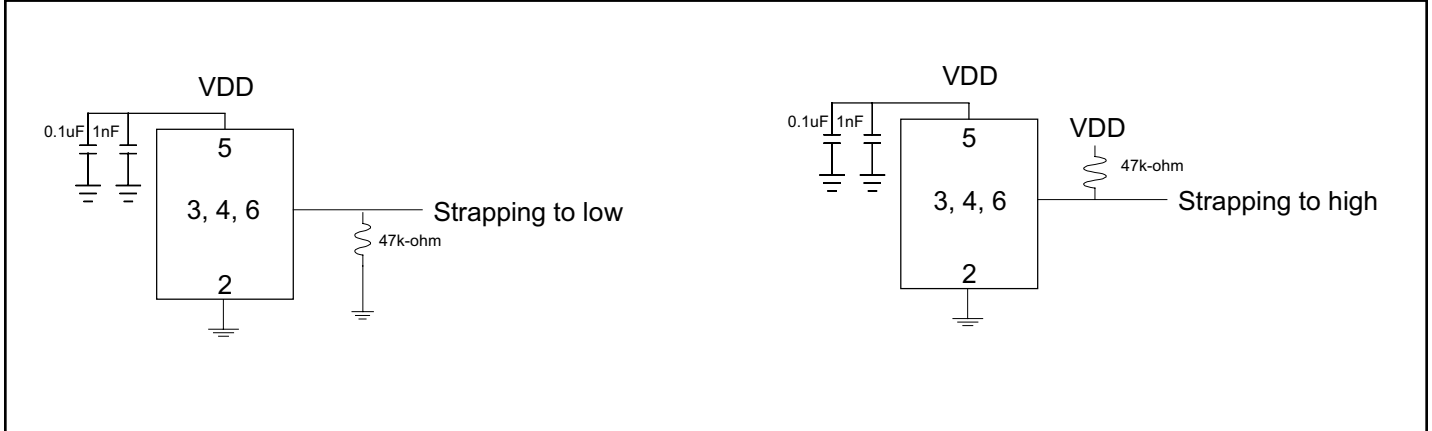

### Notes:

1. PI6C3451 accepts two kinds of clock input, a system clock generator reference and a crystal.
2. Power pin decoupling capacitors should be placed close to VDD pin and avoid using via at VDD
3. Logic state strapping:  
Pin 3 (CLK\_CPU/S0), Pin 4 (CLK\_Video/S1) and Pin 6 (X2/S2) provide logic state strapping function. When strapping resistor connects to VDD, the selection pins of S0, S1 or S2 will set to logic HIGH. When strapping resistor connects to GND, the selection pins of S0, S1 or S2 will set to logic LOW.
4. Strapping logic for spread spectrum is set to ON or OFF through S2.

### Crystal Load Capacitors

If a crystal is used with the device, the external trim capacitors  $C_{Ltrim}$  are used to adjust the effective capacitance to match the required crystal load capacitance. The  $C_{Ltrim}$  value can be derived from the formula:  $C_{Ltrim} = 2 * C_L - (C_s + C_i)$ . Typically,  $C_{Ltrim} = 28pF$  when crystal load =  $18pF$ , stray capacitance  $C_s = 3pF$ , and XTAL pins capacitance =  $5pF$ .

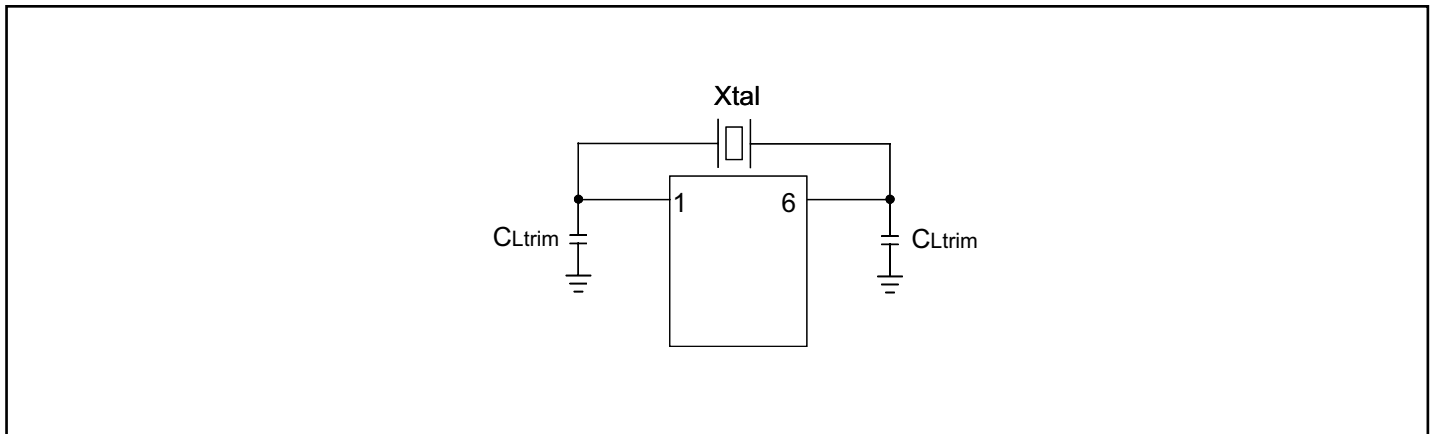

**Recommended Crystal Specifications**

(Pericom recommends NYP27.0000-18GGC-E crystal for optimum performance.)

| <b>Parameter</b>                       | <b>Value</b>                           | <b>Unit</b> |
|--|--|-------------|
| Mode of oscillation, cut               | Fundamental, AT                        |             |
| Frequency                              | 27.0000                                | MHz         |
| Frequency Tolerance                    | ±30                                    | PPM         |
| Temperature stability (-20°C to +70°C) | ±30                                    | PPM         |
| Load Capacitance                       | 18                                     | pF          |
| Equivalent series resistance           | 20                                     | Ω           |
| Size = Length x Width x Height         | 11.18(.440) x 4.65(.183) x 13.46(.530) | mm(inch)    |

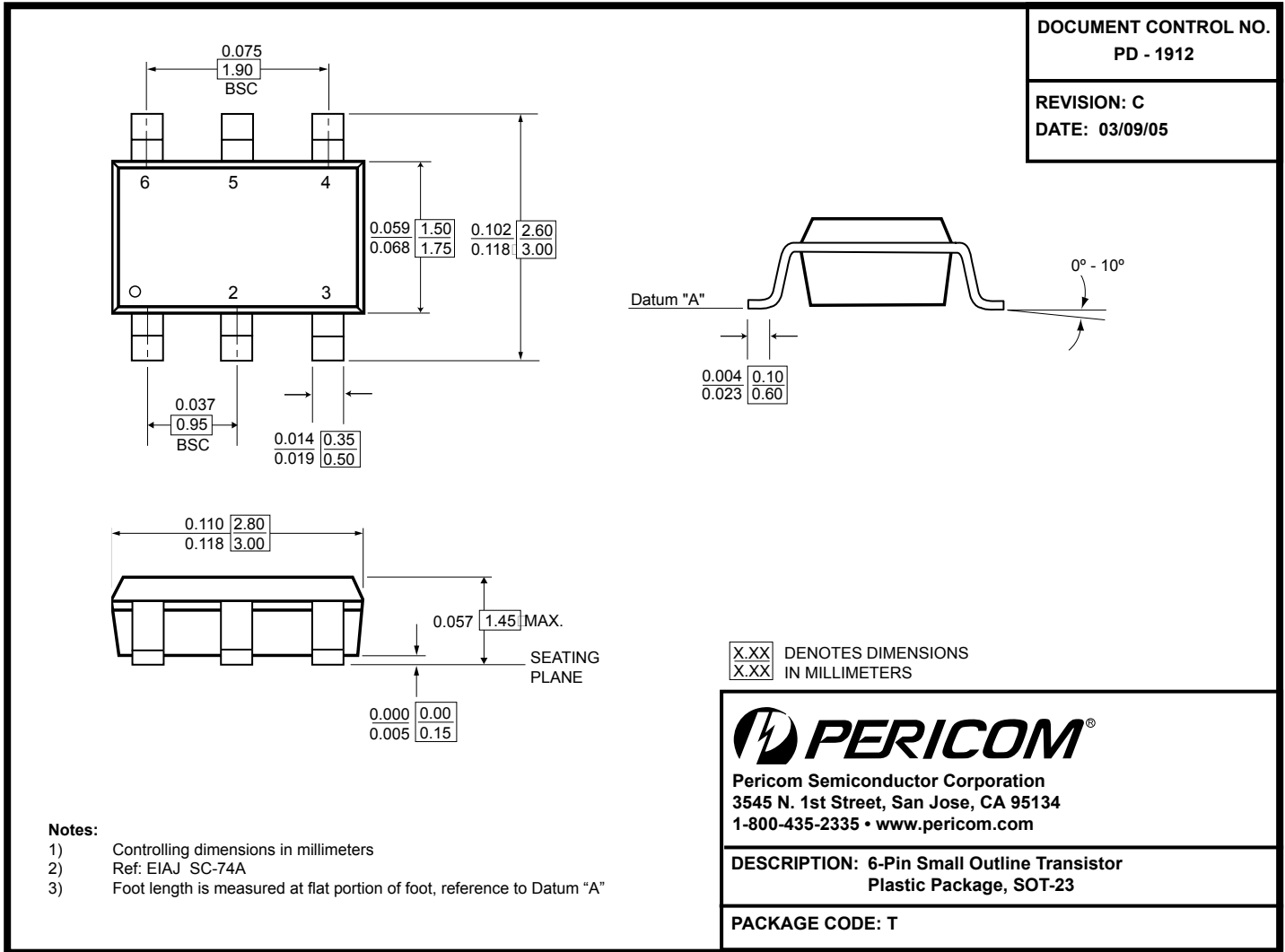

### Ordering Information (1, 2, 3)

| Ordering Code | Package Code | Package Description            |
|---------------|--------------|--------------------------------|
| PI6C3451TE    | T            | Pb-free & Green, 6-pin, SOT-23 |

**Notes:**

- Thermal characteristics can be found on the company web site at [www.pericom.com/packaging/](http://www.pericom.com/packaging/)
- E = Pb-free and Green
- X Suffix = Tape/Reel