

High-Speed USB 2.0 (480 Mbps) 1-Port Switch with Full Power Down Feature

Features

- V_{DD} Operation at 3 V and 4.3 V
- 1.8-V Compatible Control-Pin Inputs
- I_{OFF} Supports Full Power-Down Mode

Operation

- r_{on} = 5-Ohm Maximum
- Δr_{on} < 0.35-Ohm Typical
- C_{io}(ON) = 5 pF Typical
- Low Power Consumption
- ESD Performance
 - 7kV Human-Body Model, per JESD22 spec (A114-B, Class II)
 - 1000-V Charged-Device Model (C101)
 - ±4kV contact, per IEC61000-4-2
- Wide –3-dB Bandwidth = 1220 MHz Typical
- Packaged in 8-Pin TQFN (1.5 mm × 1.5 mm)

Application

- Routes Signals for USB 1.0, 1.1, and 2.0

Block Diagram

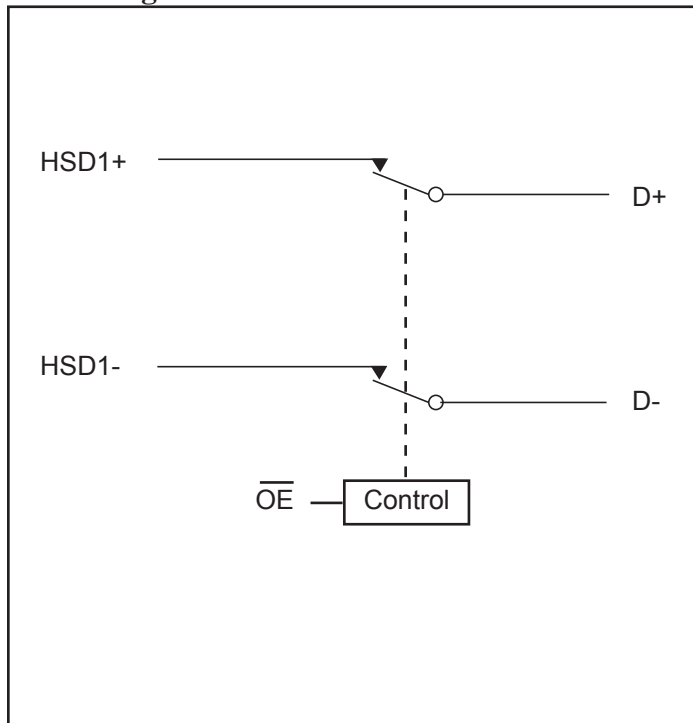

Description

The PI3USB32 is a high-bandwidth switch specially designed for the switching of high-speed USB 2.0 signals in handset and consumer applications, such as cell phones, digital cameras, and notebooks with hubs or controllers with limited USB I/Os. The wide bandwidth (750 MHz) of this switch allows signals to pass with minimum edge and phase distortion. The switch is bidirectional and offers little or no attenuation of the high-speed signals at the outputs. It is designed for low bit-to-bit skew and high channel-to-channel noise isolation, and is compatible with various standards, such as high-speed USB 2.0 (480 Mbps).

Pin Configuration

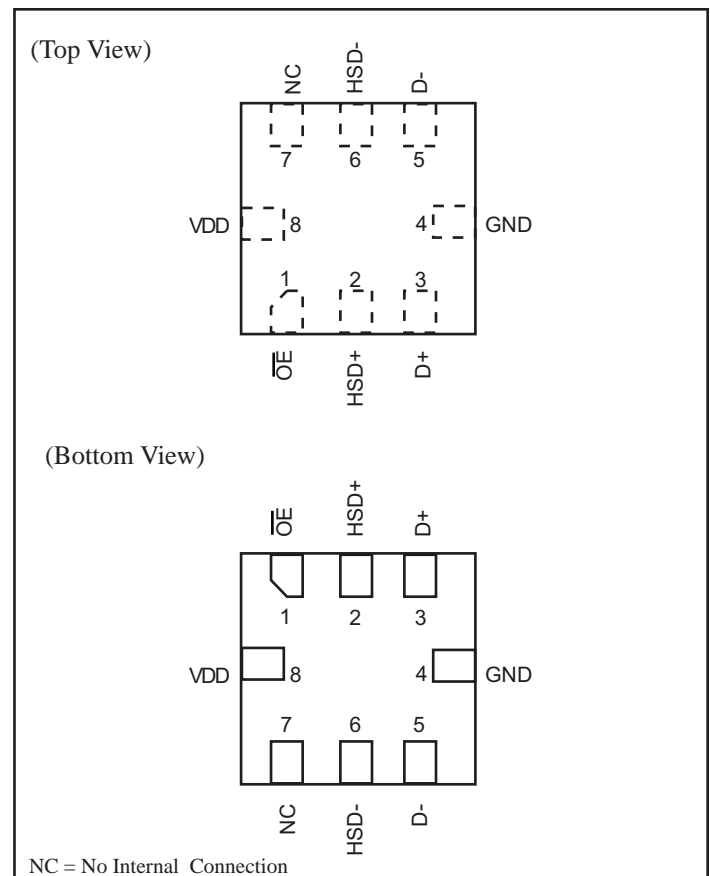

Pin Description

Name	Description
\overline{OE}	Bus-switch enable
D+, D-, HSD+, HSD-	Data ports
NC	No connect

Truth Table

\overline{OE}	Description
H	Disconnect
L	D+, D- = HSD+, HSD-

Absolute Maximum Ratings⁽¹⁾

(Over operating free-air temperature range unless otherwise noted.)

Supply Voltage Range (V_{DD}).....	-0.5V to +7V
Control Input Voltage Range (V_{IN}) ⁽²⁾⁽³⁾	-0.5V to +7V
VI/O Switch I/O Voltage Range ⁽²⁾⁽³⁾⁽⁴⁾	
HSD+, HSD-	-0.5V to $V_{DD}+0.3$
D+, D- when $V_{DD} > 0$	-0.5V to $V_{DD}+0.3$
D+, D- when $V_{DD} > 0$	5.25V
Control Input Clamp Current	-50 mA
I/O Port Clamp Current.....	-50 mA
ON-state switch current ⁽⁵⁾	± 64 mA
Continuous current through V_{DD} or GND	± 100 mA
I/O Port Clamp Current.....	-50 mA

Note:

(1) Stresses greater than those listed under MAXIMUM RATINGS may cause permanent damage to the device. This is a stress rating only and functional operation of the device at these or any other conditions above those indicated in the operational sections of this specification is not implied. Exposure to absolute maximum rating conditions for extended periods may affect reliability.

(2) All voltages are with respect to ground, unless otherwise specified.

(3) The input and output voltage ratings may be exceeded if the input and output clamp-current ratings are observed.

(4) V_I and V_O are used to denote specific conditions for $V_{I/O}$.

(5) I_I and I_O are used to denote specific conditions for $I_{I/O}$.

Recommended Operating Conditions⁽¹⁾

Parameter	Description	Min.	Max.	Units
V _{DD}	Supply voltage	3.0	4.3	V
V _{IH}	High-level control input voltage	V _{DD} = 3V to 3.6V 1.3		V
		V _{DD} = 4.3 V 1.7		
V _{IL}	Input LOW Voltage	V _{DD} = 3V to 3.6V 0.5		V
		V _{DD} = 4.3 V 0.6		
V _{I/O}	Data input/output voltage	0	V _{DD}	V
T _A	Operating free-air temperature	-40	85	°C

Notes:

- All unused control inputs of the device must be held at V_{DD} or GND to ensure proper device operation.

Electrical Characteristics over operating free-air temperature range (unless otherwise noted)

PARAMETER		TEST CONDITIONS ¹	MIN	TYP ⁽²⁾	MAX	UNIT
V _{IK}		V _{DD} = 3 V, I _I = -18 mA			-1.2	V
I _{IN}	Control inputs	V _{DD} = 4.3 V, V _{IN} = 0 to 4.3 V, V _{DD} = 0 V			±1	μA
I _{OZ} ⁽³⁾		V _{DD} = 4.3 V, V _O = 0 to 3.6V, V _I = 0, Switch OFF			±1	μA
I _{OFF}	D+ and D-	V _{DD} = 0 V, V _O = 0 to 4.3 V, V _I = 0, V _{IN} = V _{DD} or GND			±2	μA
I _{CC}		V _{DD} = 4.3 V, I _{I/O} = 0			70	μA
ΔI _{CC} ⁽⁴⁾	Control inputs	V _{DD} = 4.3 V, V _{IN} = 2.6 V			10	μA
C _{IN}	Control inputs	V _{DD} = 0 V, V _{IN} = V _{DD} or GND		1		pF
C _{io} (OFF)		V _{DD} = 3.3 V, Switch OFF		2		pF
C _{io} (ON)		V _{DD} = 3.3 V, Switch ON		5		pF
R _{ON} ⁽⁵⁾		V _{DD} = 3 V, V _I = 0.4 V, I _O = -8 mA		6	10	Ω
ΔR _{ON}		V _{DD} = 3 V, V _I = 0.4 V, I _O = -8 mA		0.35		Ω
ΔR _{ON} (flat)		V _{DD} = 3 V, V _I = 0 V or 1 V, I _O = -8 mA		2		Ω

Notes:

- V_{IN} and I_{IN} refer to control input ($\overline{\text{OE}}$). V_I, V_O, I_I, and I_O refer to data pins.
- All typical values are at V_{DD} = 3.3 V (unless otherwise noted), T_A = 25°C.
- For I/O ports, the parameter I_{OZ} includes the input leakage current.
- This is the increase in supply current for each input that is at the specified TTL voltage level, rather than V_{DD} or GND.
- Measured by the voltage drop between the D and HSD terminals at the indicated current through the switch. ON-state resistance is determined by the lower of the voltages of the two terminals.

Dynamic Electrical Characteristics (over operating range, $T_A = -40^{\circ}\text{C}$ TO 85°C , $V_{DD} = 3.3\text{ V} \pm 10\%$, $GND = 0\text{ V}$)

Parameter	Description	Test Conditions ⁽¹⁾	Typ. ⁽¹⁾	Units
O _{IRR}	OFF isolation	$R_L = 50\text{-Ohms}$, $f = 240\text{ MHz}$	-30	dB
BW	Bandwidth (-3 dB)	$R_L = 50\text{-Ohms}$	2110	MHz
Xtalk	Crosstalk	$R_L = 50\text{-Ohms}$, $f = 240\text{ MHz}$	-55	dB

Notes:

1. For Max or Min conditions, use the appropriate value specified under Electrical Characteristics for the applicable device type.

Switching Characteristics (over operating range, $T_A = -40^{\circ}\text{C}$ TO 85°C , $V_{DD} = 3.3\text{ V} \pm 10\%$, $GND = 0\text{ V}$)

Parameters	Description	Test Conditions ⁽¹⁾	Min.	Typ.	Max.	Units
t _{PD}	Propagation Delay ^(2,3)	$R_L = 50\ \Omega$, $C_L = 5\text{ pF}$			0.35	ns
t _{ON}	Line Enable Time, \overline{OE} to D+/D-	$R_L = 50\ \Omega$, $C_L = 5\text{ pF}$			55	ns
t _{OFF}	Line Disable Time - \overline{OE} to D+/D-	$R_L = 50\ \Omega$, $C_L = 5\text{ pF}$			25	ns
t _{SK(P)}	Skew between opposite transitions of the same output (t _{PHL} - t _{PLH}) ²	$R_L = 50\ \Omega$, $C_L = 5\text{ pF}$		50		ps
t _J	Total Jitter ²	$R_L = 50\ \Omega$, $C_L = 5\text{ pF}$, $t_R = t_F = 500\text{ ps}$ at 480 Mbps (PBRs = $2^{15} - 1$)		200		ps

Notes:

- For Max or Min conditions, use the appropriate value specified under Electrical Characteristics for the applicable device type.
- Guaranteed by design.
- The bus switch contributes no propagational delay other than the RC delay of the on resistance of the switch and the load capacitance. The time constant for the switch alone is of the order of 0.25 ns for 10-pF load. Since this time constant is much smaller than the rise/fall times of typical driving signals, it adds very little propagational delay to the system. Propagational delay of the bus switch, when used in a system, is determined by the driving circuit on the driving side of the switch and its interactions with the load on the driven side.

Application Information

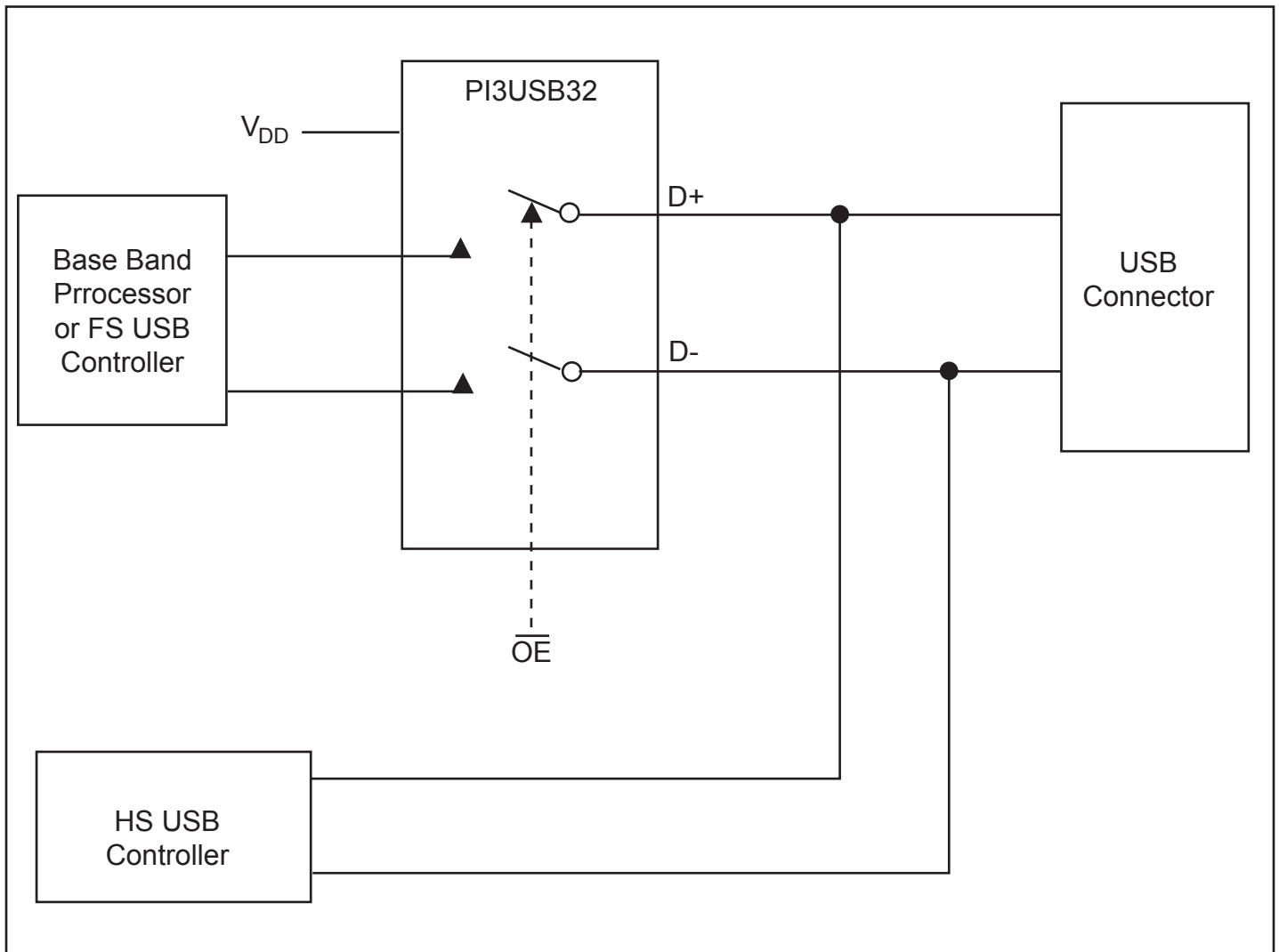

Application Diagram

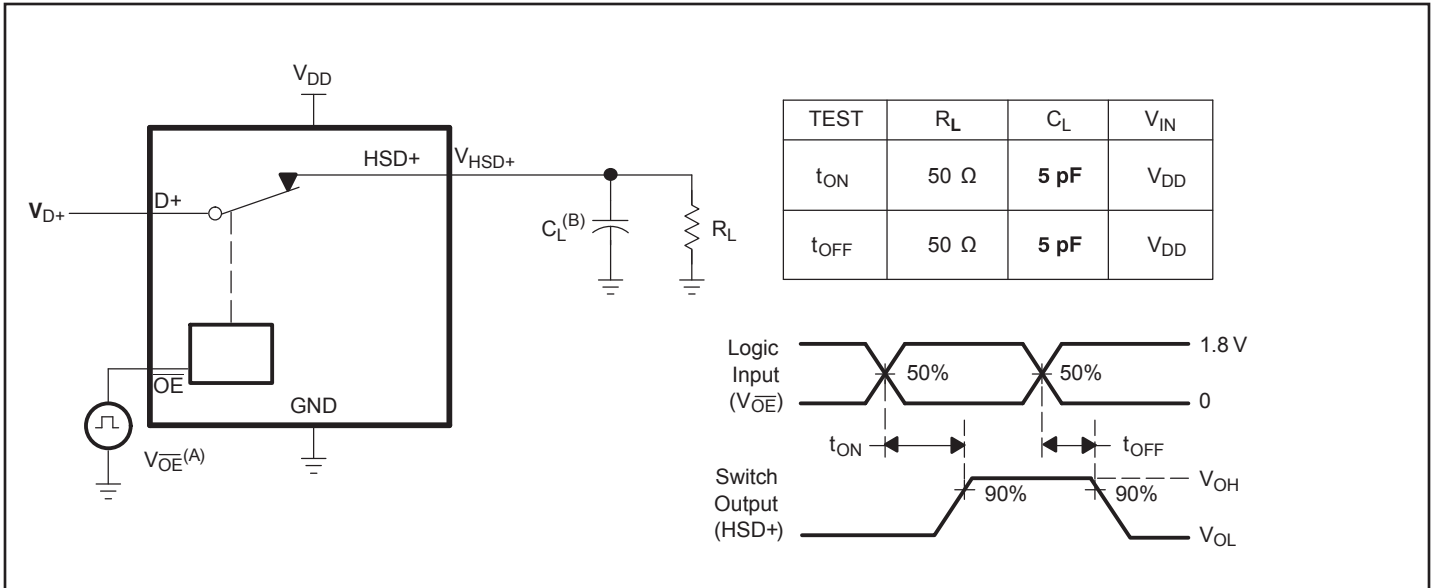
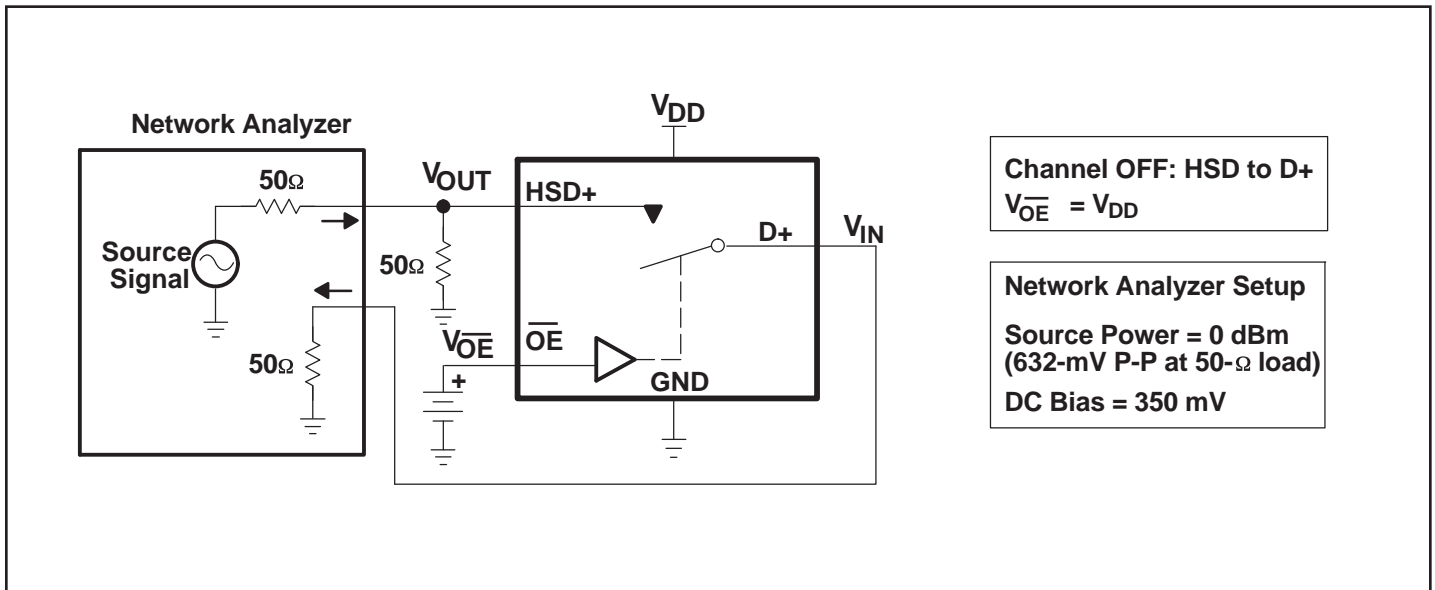
Turn-On (t_{ON}) and Turn-Off Time (t_{OFF})

Figure 8. OFF Isolation (OIRR)

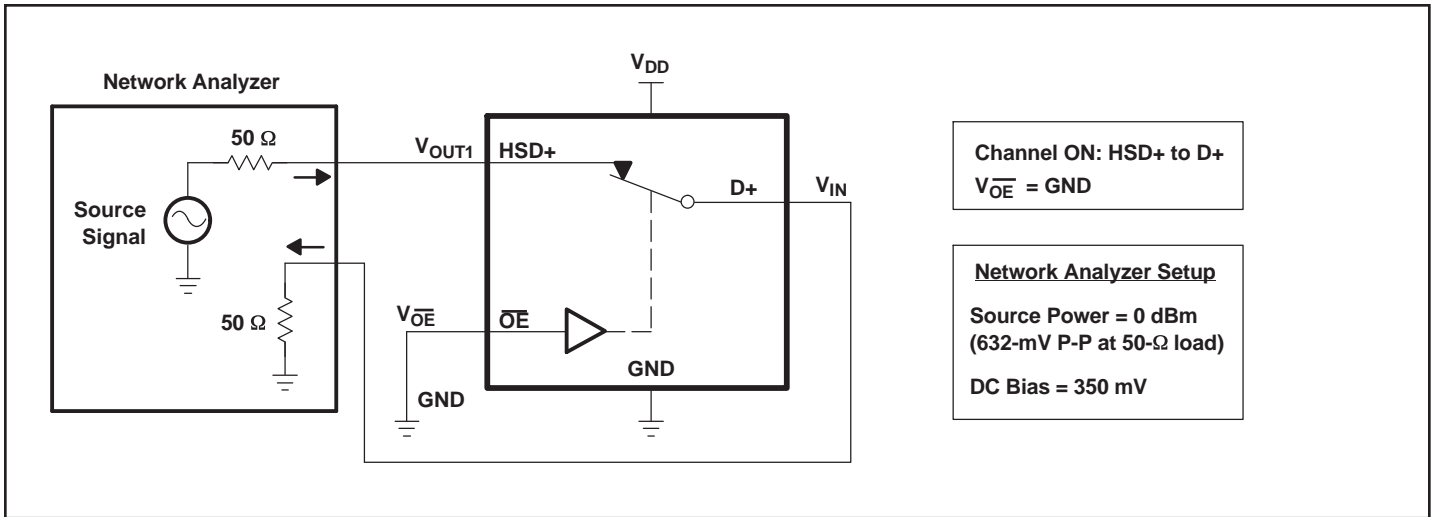

Figure 10. Bandwidth (BW)

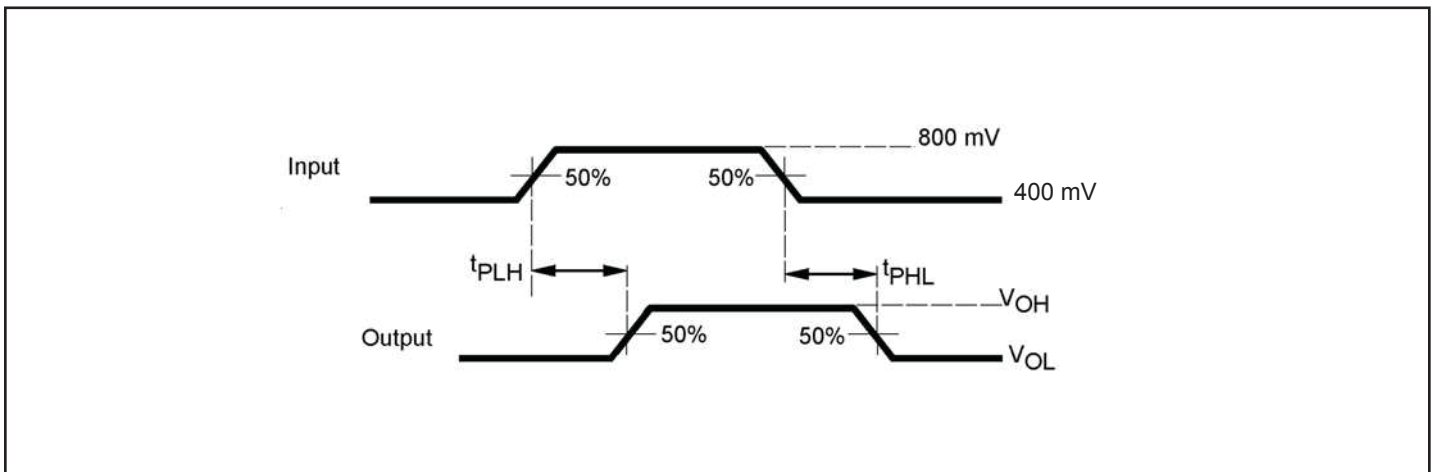
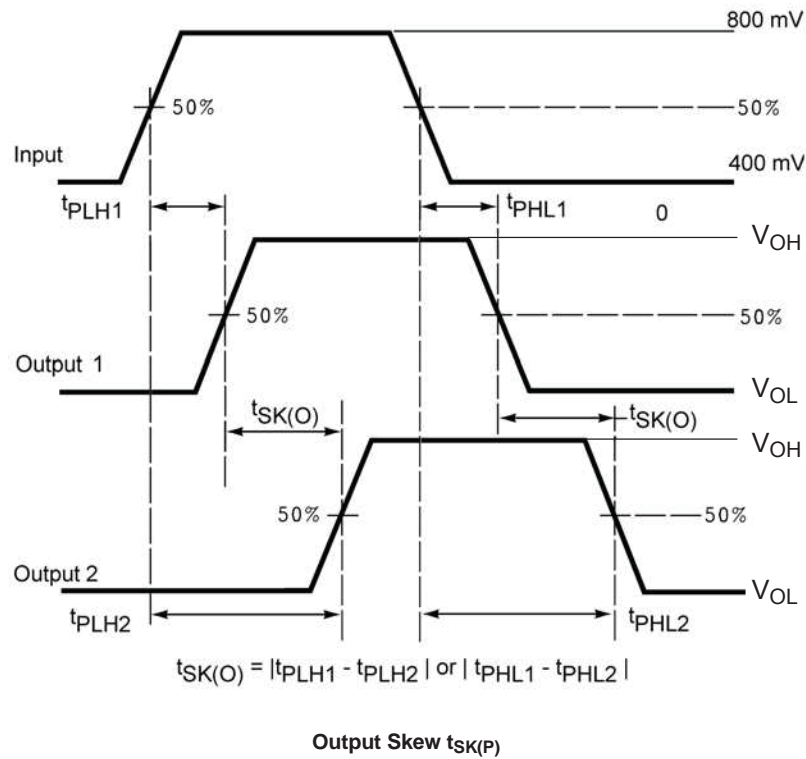
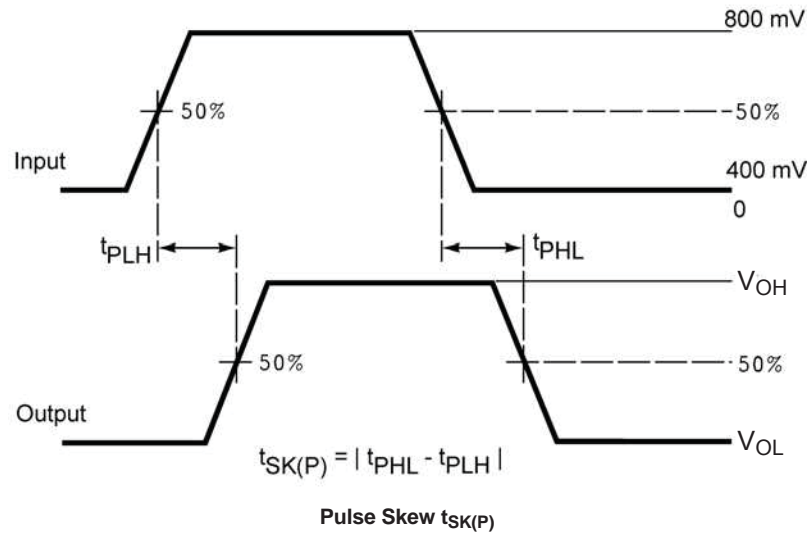
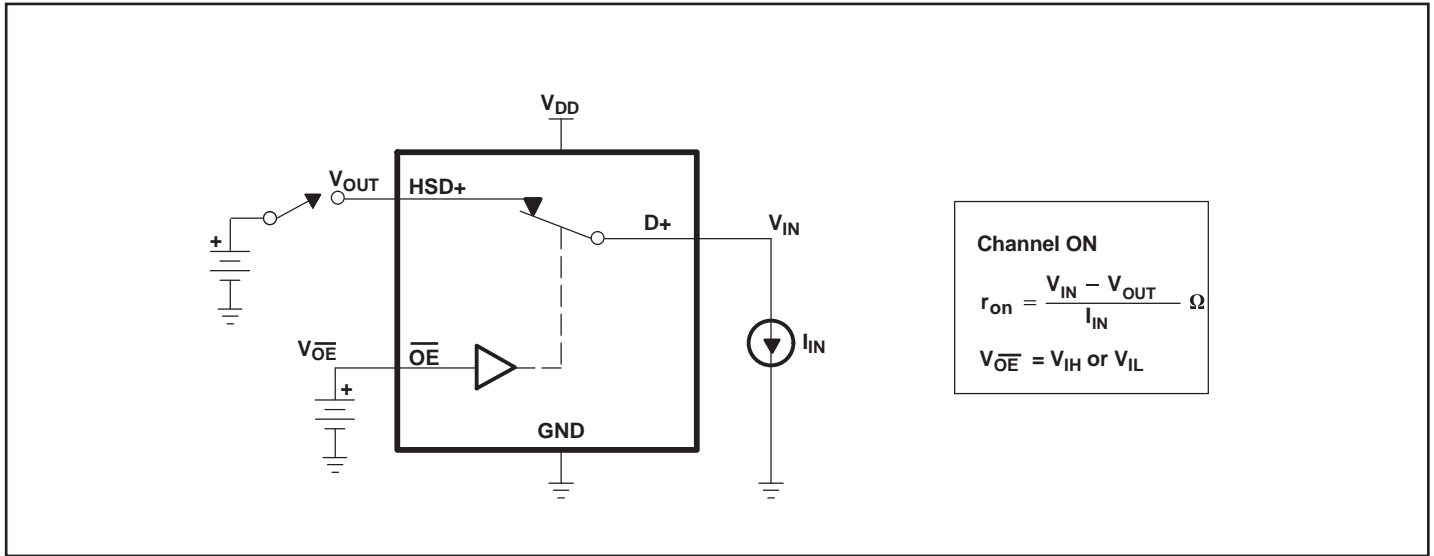
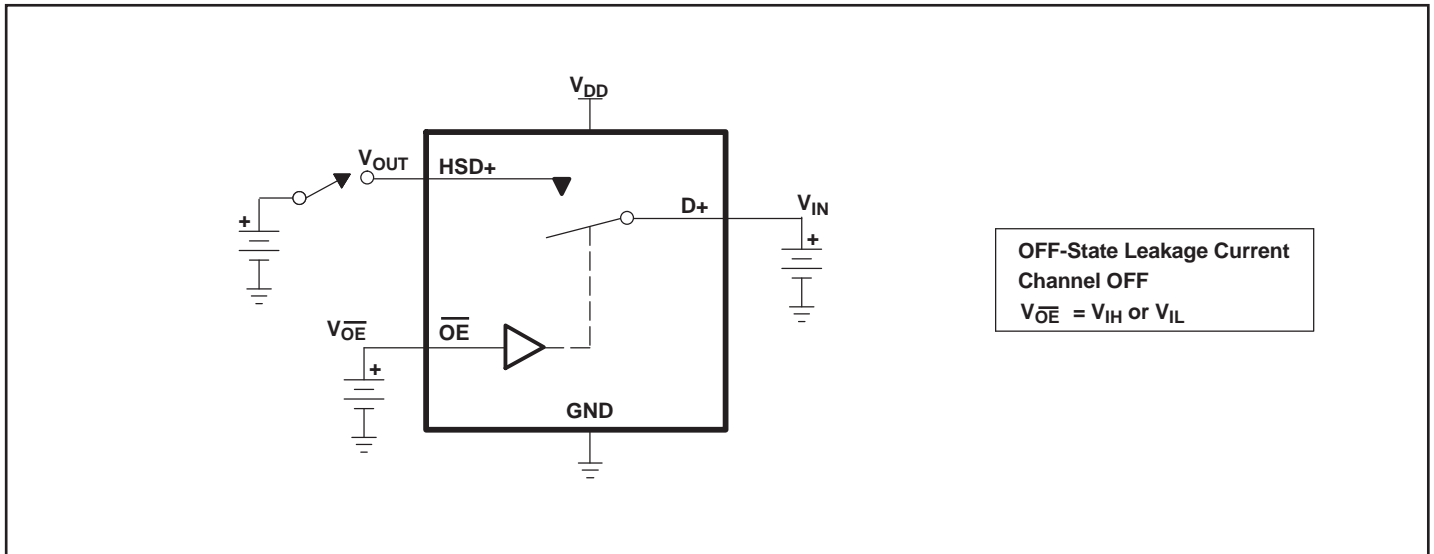

Figure 11. Propagation Delay



Skew Test



ON-State Resistance (r_{on})

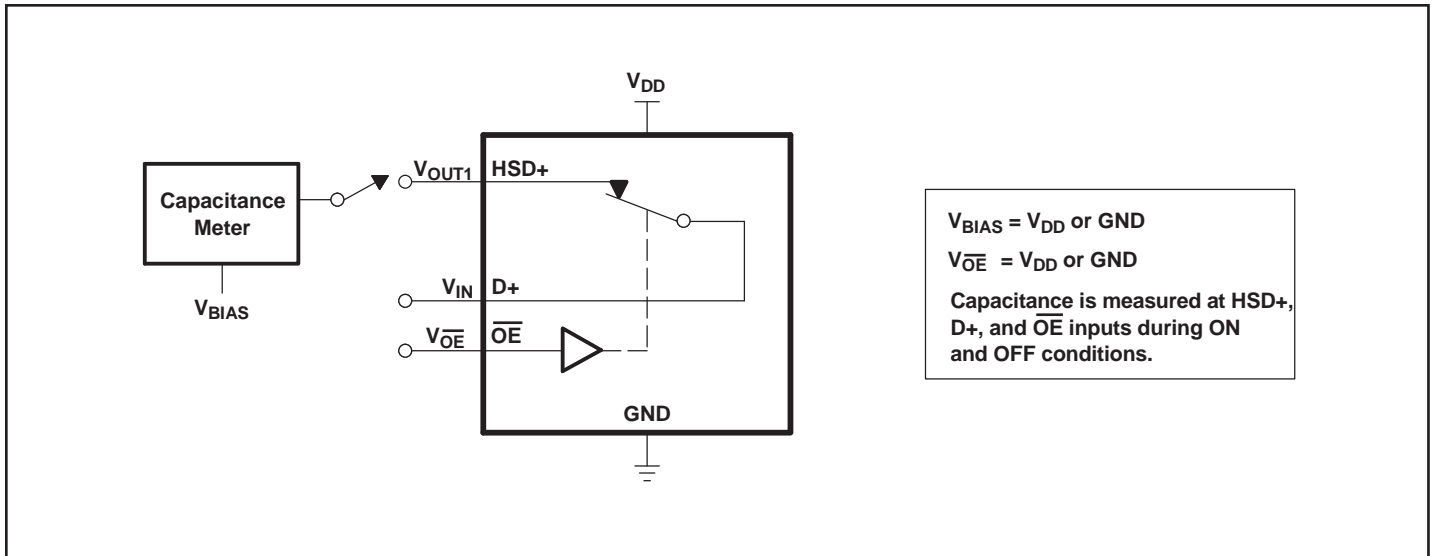

OFF-State Leakage Current



$V_{BIAS} = V_{DD}$ or GND
 $V_{\overline{OE}} = V_{DD}$ or GND
 Capacitance is measured at HSD+,
 D+, and \overline{OE} inputs during ON
 and OFF conditions.

Capacitance

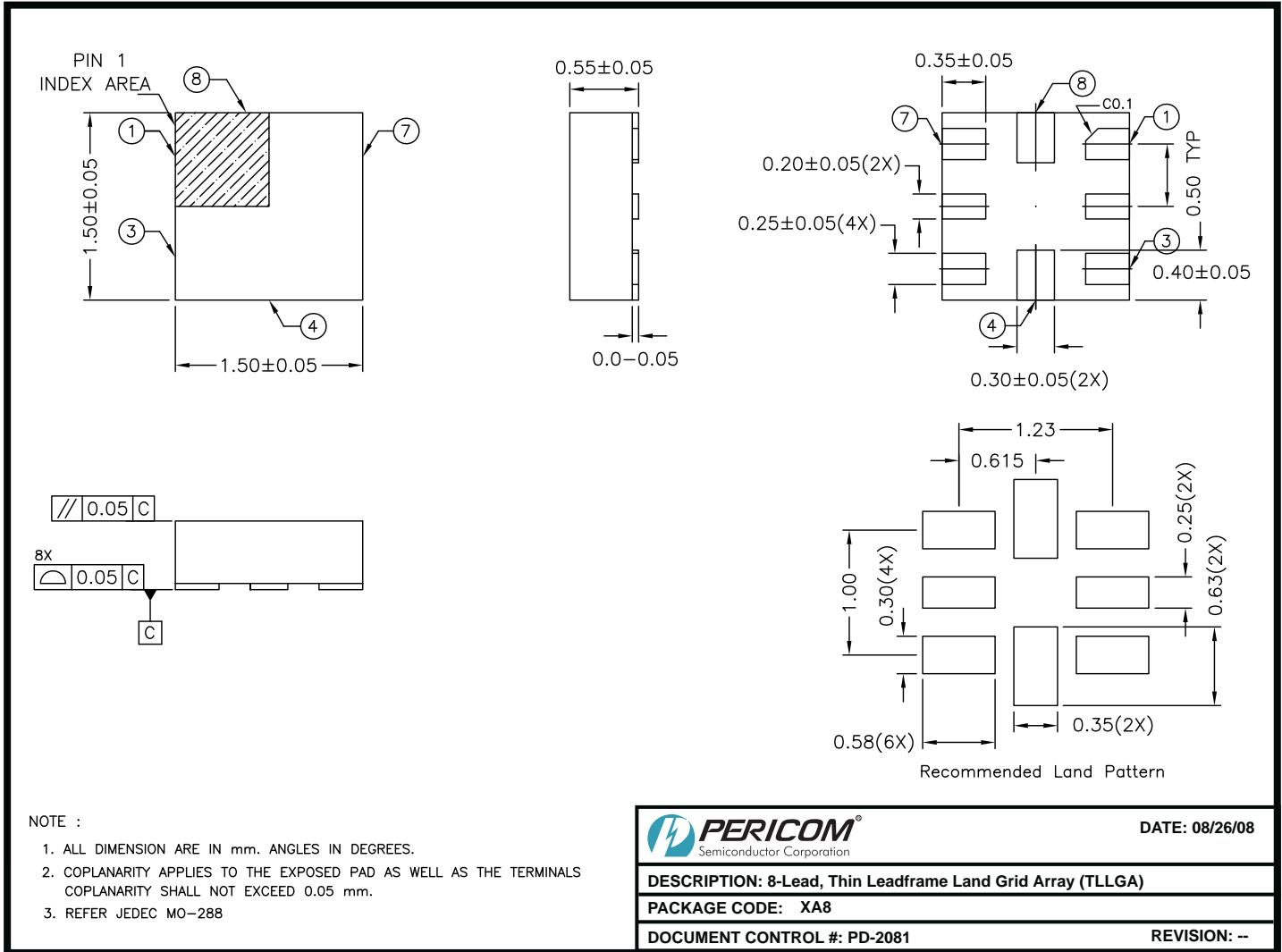

PD-2081

Ordering Information

Ordering Code	Package Code	Package Description	Top Mark
PI3USB32XAE	XA	8-pin, TQFN	EK

Notes:

- Thermal characteristics can be found on the company web site at www.pericom.com/packaging/
- E = Pb-free and Green
- Adding X suffix = Tape/Reel