

---

**4-Differential Channel, 3:1 Mux/DeMux, DVI/HDMI<sup>™</sup> Compliant  
Signal Switch based on TMDS Signaling Standard****Features**

- 4-Differential Channel 3:1 Mux/DeMux
- HDMI<sup>™</sup> 1.1, 1.2, and 1.3 compatible
- Supports both AC coupled & DC coupled signals
- Max Data Rate: 4.0 Gbps
- Crosstalk: -30dB @ 1.65 Gbps
- Switching speed: 4ns
- Isolation: -40dB @ 1.65 Gbps
- ESD: Data bits @ 8kV contact (Typ)
- Near-Zero Prop Delay: 250ps max.
- Low bit-to-bit skew
- Enable/Disable Time: 9ns
- Bidirectional
- Packaging (Pb-free & Green):  
— 80-pin BQSOP (B80)

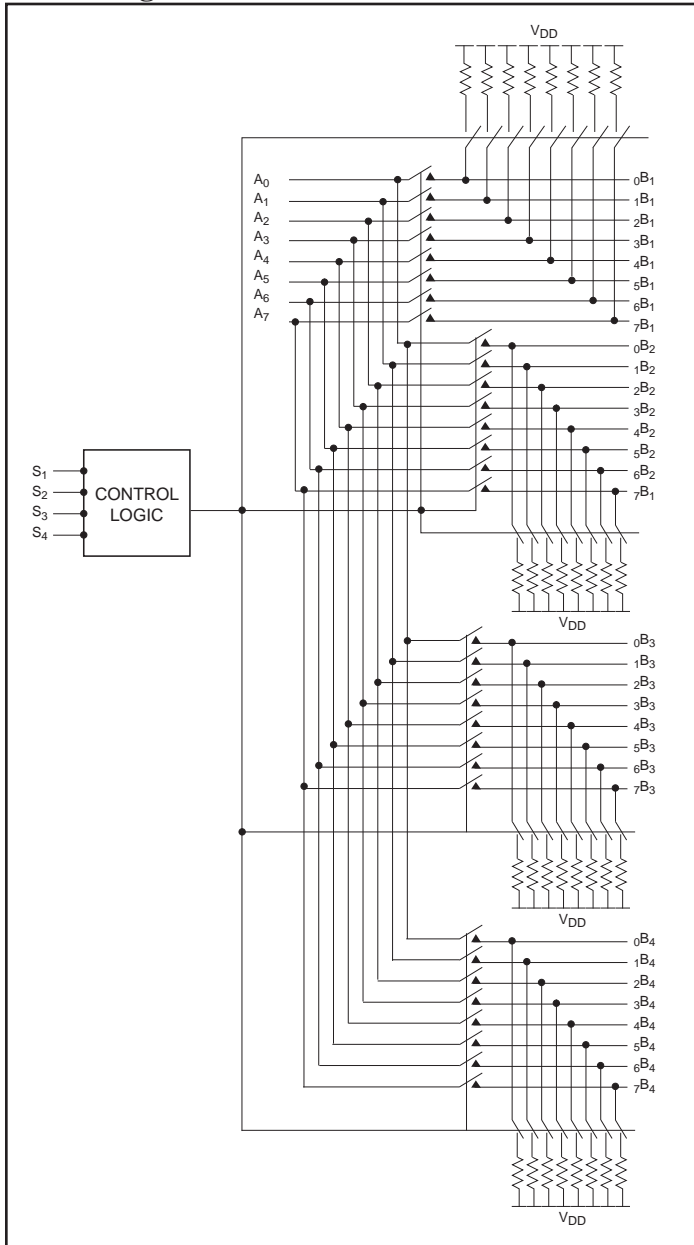
**Description**

Pericom Semiconductor's PI3HDMI<sup>™</sup> series of switch circuits are targeted for high-resolution video networks that are based on DVI/HDMI standards, and TMDS signal processing. The PI3HDMI413-A is a 12- to 4-Differential Channel Mux/DeMux Switch. The device multiplexes differential signals to one of three corresponding outputs. The switch is bidirectional and offers little or no attenuation of the high-speed signals at the outputs. It is designed for low bit-to-bit skew and high channel-to-channel noise isolation.

The maximum DVI/HDMI data rate of 4.5Gbps provides the resolution required by the next generation HDTV and PC graphics.

Because of its passive bidirectional feature, this switch can be used either at the video drivers side or at the receiver side. For PC graphics applications, the device sits at the drivers side to switch between multiple display units such as PC LCD monitor, projector, TV, etc. For consumer video applications, the device sits at the receiver end to switch between the source components such as DVD, D-VHS, STB, etc.

### Block Diagram



### Pin Description (B80)

VDD	1	80	VDD
VSS	2	79	0B1
VSS	3	78	1B1
S1	4	77	2B1
S2	5	76	3B1
VSS	6	75	0B2
VDD	7	74	1B2
A0	8	73	2B2
A1	9	72	3B2
VSS	10	71	VSS
A2	11	70	VDD
A3	12	69	0B3
VDD	13	68	1B3
VSS	14	67	2B3
VSS	15	66	3B3
VDD	16	65	VSS
VSS	17	64	VSS
VSS	18	63	VSS
VSS	19	62	VSS
VDD	20	61	VSS
VDD	21	60	VDD
VSS	22	59	4B1
VSS	23	58	5B1
S3	24	57	6B1
S4	25	56	7B1
VSS	26	55	4B2
VDD	27	54	5B2
A4	28	53	6B2
A5	29	52	7B2
VSS	30	51	VSS
A6	31	50	VDD
A7	32	49	4B3
VDD	33	48	5B3
VSS	34	47	6B3
VSS	35	46	7B3
VDD	36	45	VSS
VSS	37	44	VSS
VSS	38	43	VSS
VSS	39	42	VSS
VDD	40	41	VDD

**Pin Description (B80)**

Pin #	Pin Name	Description
1,7,13,16,20,21,27,33,36,40,41,50,60,61,70,80	V <sub>DD</sub>	+ Power supply 3.30
2,3,6,10,14,15,17,18,19,22,23,26,30,34,35,37,38,39,42-45,51,62-65,71	V <sub>SS</sub>	- Power supply
4,5,24,25	S <sub>x</sub>	Select pin, see truth table
8,9,11,12,28,29,31,32,46-49,52-59,66-69,72-79	xBy & Ax	Differential data signals

**Truth Table for X=[0,3]**

S2	S1	Function
0	0	A <sub>x</sub> = xB <sub>1</sub>
0	1	A <sub>x</sub> = xB <sub>2</sub>
1	0	A <sub>x</sub> = xB <sub>3</sub>
1	1	A <sub>x</sub> = Hi-Z

**Truth Table for X=[4,7]**

S4	S3	Function
0	0	A <sub>x</sub> = xB <sub>1</sub>
0	1	A <sub>x</sub> = xB <sub>2</sub>
1	0	A <sub>x</sub> = xB <sub>3</sub>
1	1	A <sub>x</sub> = Hi-Z

**Maximum Ratings**

(Above which useful life may be impaired. For user guidelines, not tested.)

Storage Temperature .....	-65°C to +150°C
Supply Voltage to V <sub>SS</sub> Potential.....	-0.5V to +2.5V
DC Input Voltage .....	V <sub>SS</sub> to V <sub>DD</sub>
DC Output Current .....	120mA
Power Dissipation .....	0.5W

**Note:** Stresses greater than those listed under MAXIMUM RATINGS may cause permanent damage to the device. This is a stress rating only and functional operation of the device at these or any other conditions above those indicated in the operational sections of this specification is not implied. Exposure to absolute maximum rating conditions for extended periods may affect reliability.

**DC Power Supply Characteristics**

Parameter	Description	Min.	Max.	Units
V <sub>DD</sub>	Positive Power Supply	3.0	3.6	V
V <sub>SS</sub>	Negative Power Supply	1.5	1.6	V

**DC Electrical Characteristics for Switching over Operating Range** ( $T_A = -40^{\circ}\text{C}$  to  $+85^{\circ}\text{C}$ )

Parameter	Description	Test Conditions <sup>(1)</sup>	Min.	Typ. <sup>(2)</sup>	Max.	Units
$V_{IH}^{(3)}$	Input HIGH Voltage	Guaranteed HIGH level	$0.65(V_{DD}-V_{SS})+V_{SS}$			V
$V_{IL}^{(3)}$	Input LOW Voltage	Guaranteed LOW level	$-0.5+V_{SS}$		$0.35(V_{DD}-V_{SS})+V_{SS}$	
$V_{IK}$	Clamp Diode Voltage	$V_{DD}=\text{Max.}, I_{IN}=-18\text{mA}$		$-0.7+V_{SS}$	$-1.2+V_{SS}$	$\mu\text{A}$
$I_{IH}$	Input HIGH Current	$V_{DD}=\text{Max.}, V_{IN}=V_{DD}$			$\pm 5$	
$I_{IL}$	Input LOW Current	$V_{DD}=\text{Max.}, V_{IN}=V_{SS}$			$\pm 5$	

**Notes:**

- For Max. or Min. conditions, use appropriate value specified under Electrical Characteristics for the applicable device type.
- Typical values are at  $T_A = 25^{\circ}\text{C}$  ambient and maximum loading.
- $V_{IH} + V_{IL}$  are for SEL input only.

**Power Supply Characteristics**

Parameters	Description	Test Conditions <sup>(1)</sup>	Min.	Typ. <sup>(2)</sup>	Max.	Units
$I_{CC}$	Quiescent Power Supply Current	$V_{DD} = \text{Max.}, V_{IN} = V_{DD}$ or $V_{SS}$		500	600	$\mu\text{A}$

**Notes:**

- For Max. or Min. conditions, use appropriate value specified under Electrical Characteristics for the applicable device type.
- Typical values are at  $T_A = 25^{\circ}\text{C}$  ambient and maximum loading.

**Dynamic Electrical Characteristics Over the Operating Range** ( $T_A = -40^{\circ}$  to  $+85^{\circ}\text{C}$ )

Parameter <sup>(1)</sup>	Description	Test Conditions	Min.	Typ. <sup>(2)</sup>	Max.	Units
$X_{\text{TALK}}$	Crosstalk	See Fig. 1 for Measurement Setup, @ 1.65Gbps		-30		dB
$O_{\text{IRR}}$	OFF Isolation	See Fig. 2 for Measurement Setup, @ 1.65 Gbps		-40		
-3dB BW	-3dB bandwidth			2		GHz
Insertion Loss		@ 1.65 Gbps 8-bits color/channel		-0.90		dB
		@ 2.0 Gbps 10-bits color/channel		-1.05		
		@ 2.5 Gbps 12-bits color/channel		-1.35		
		@ 3.3 Gbps 16-bits color/channel		-2.20		

**Notes:**

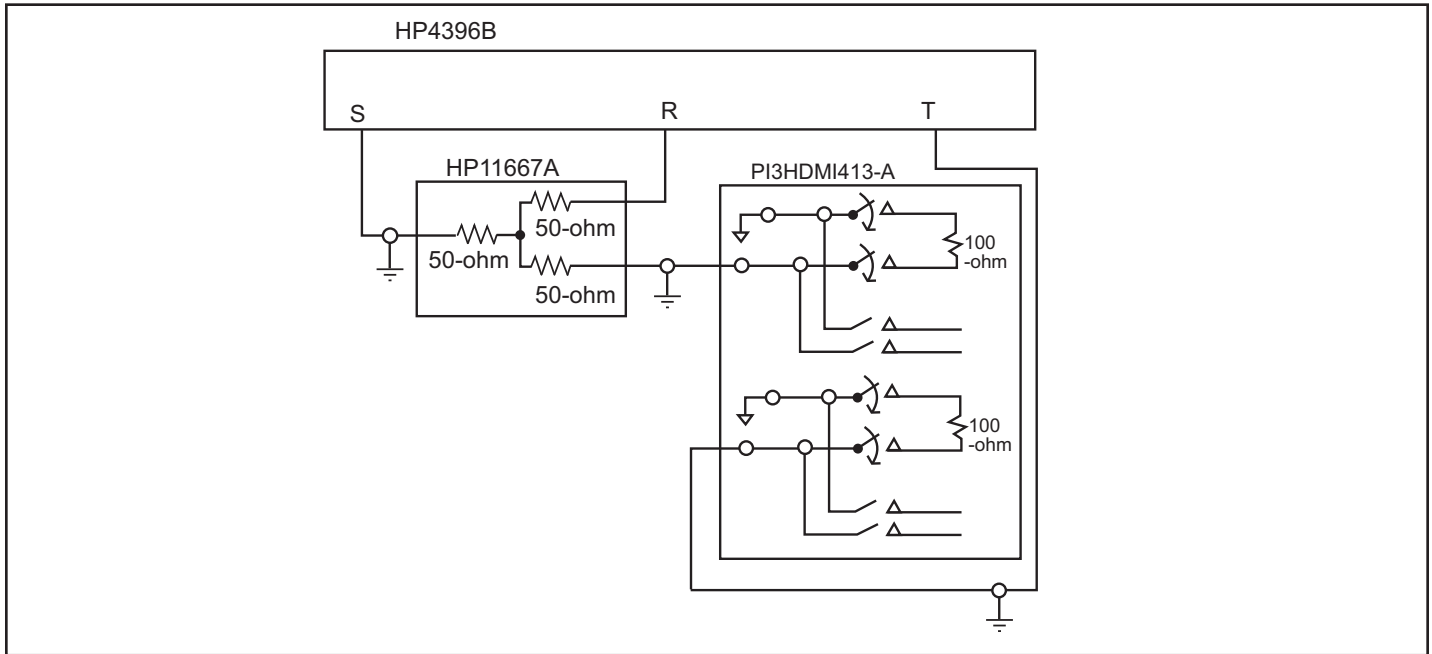
- Guaranteed by design.
- Typical values are at  $T_A = 25^{\circ}\text{C}$  ambient and maximum loading.

**Switching Characteristics** ( $T_A = -40^{\circ}$  to  $+85^{\circ}\text{C}$ ,  $V_{SS}=0\text{V}$ ,  $V_{DD}=1.8\text{V} \pm 10\%$ )

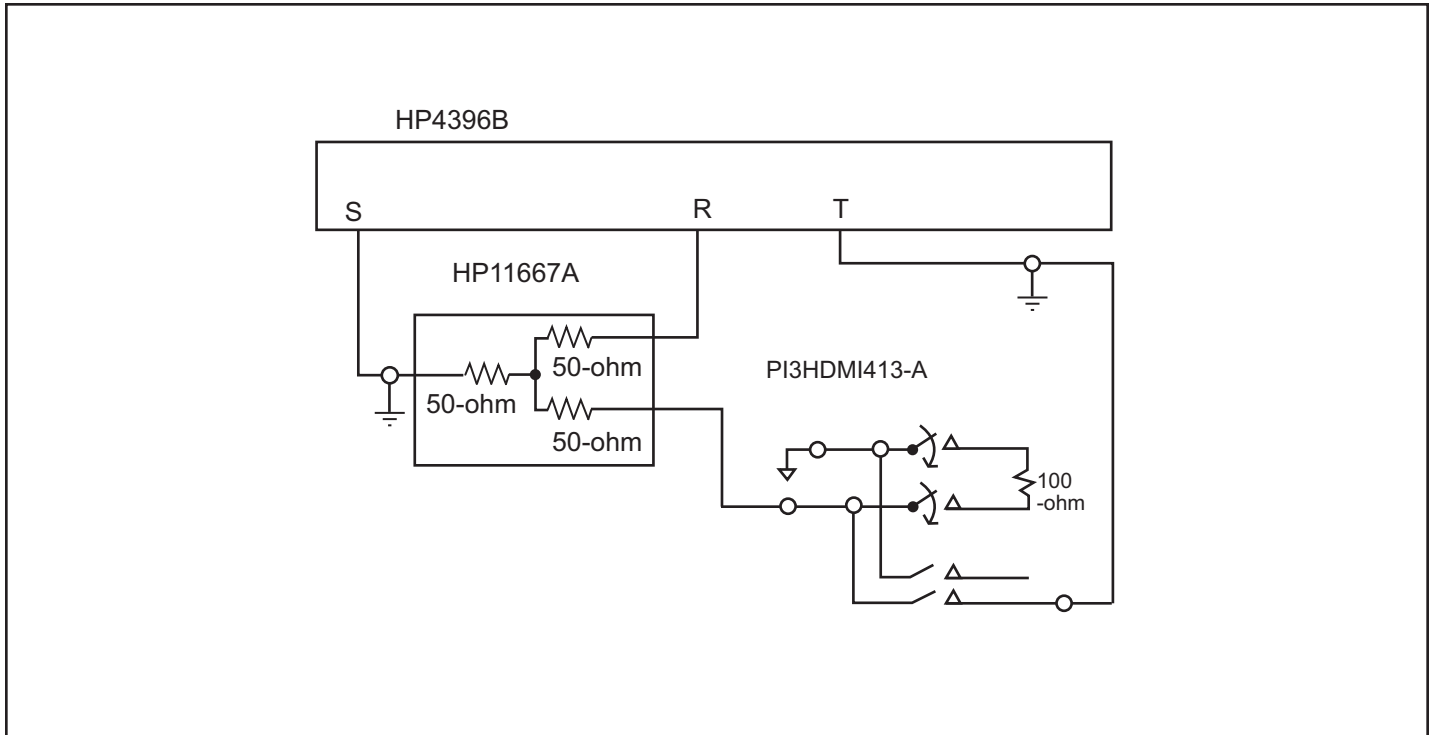
Parameter	Description <sup>(1)</sup>	Min.	Max.	Units
$t_{\text{PZH}}, t_{\text{PZL}}$	Line Enable Time - SEL to $A_N, B_N$	0.5	8.0	nS
$t_{\text{PHZ}}, t_{\text{PLZ}}$	Line Disable Time - SEL to $A_N, B_N$	0.5	4.0	

**Note:**

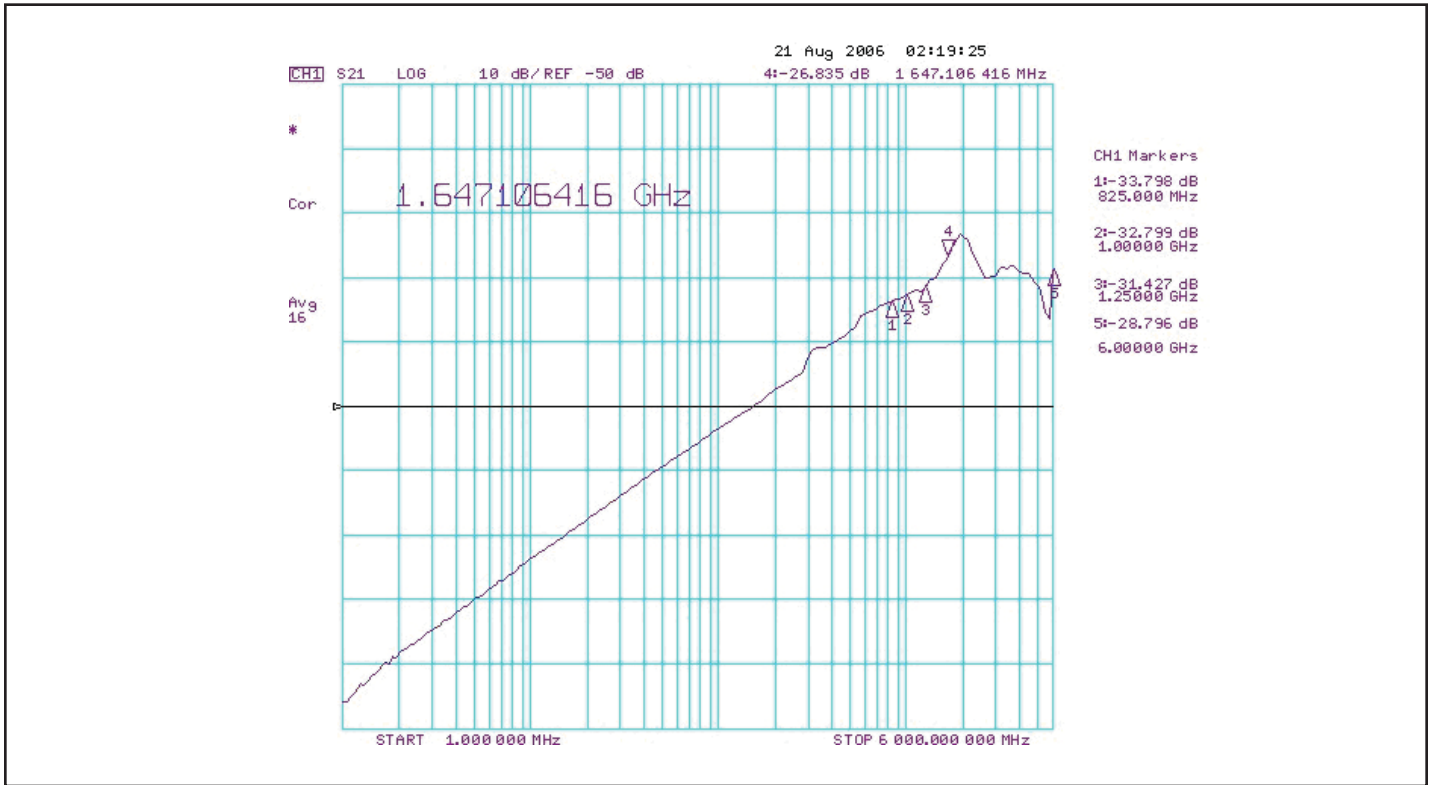
- For measurement setup, please see “Test Circuit For Electrical Characteristic” on page 6, and “Switching waveforms” on page 7



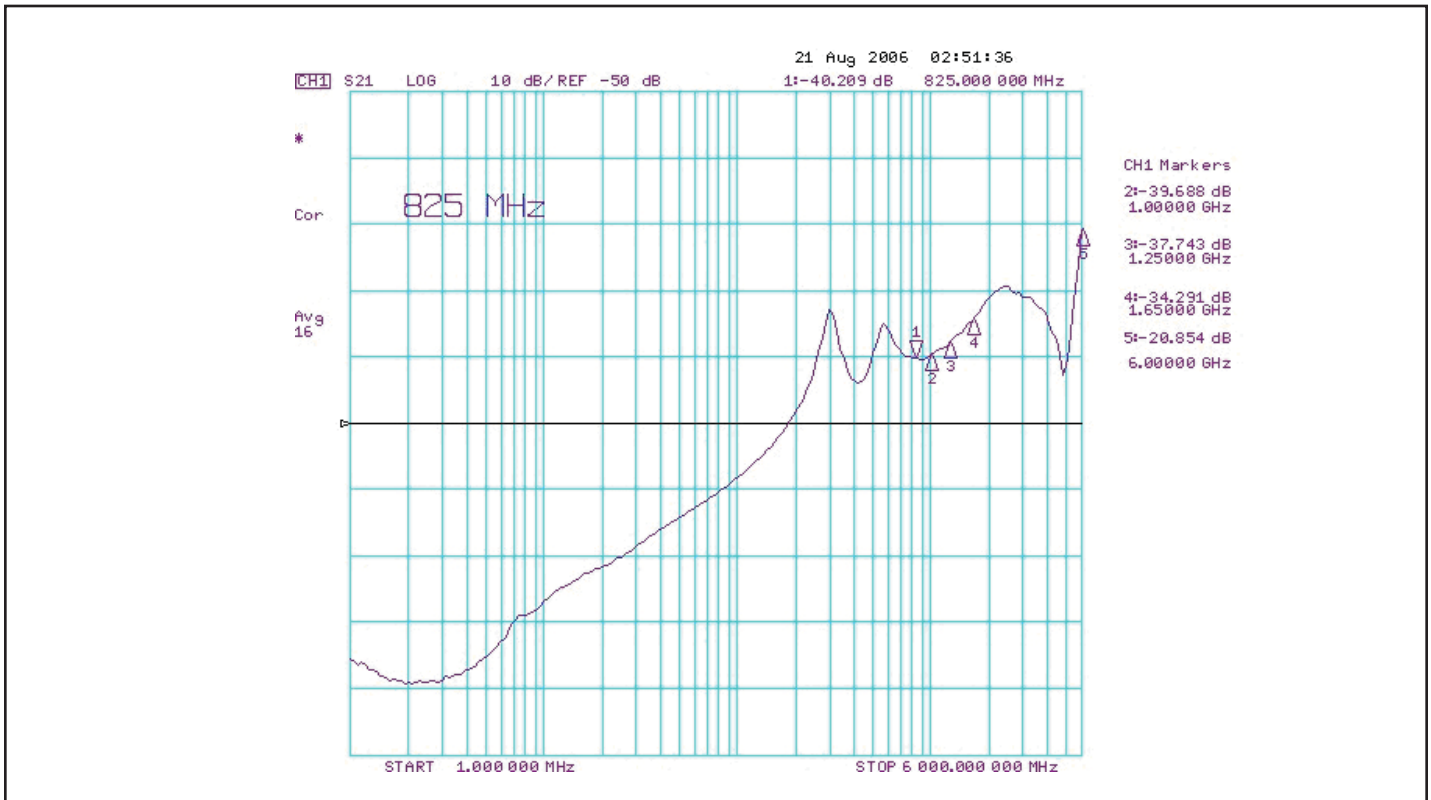
**Fig 1. Crosstalk Setup**



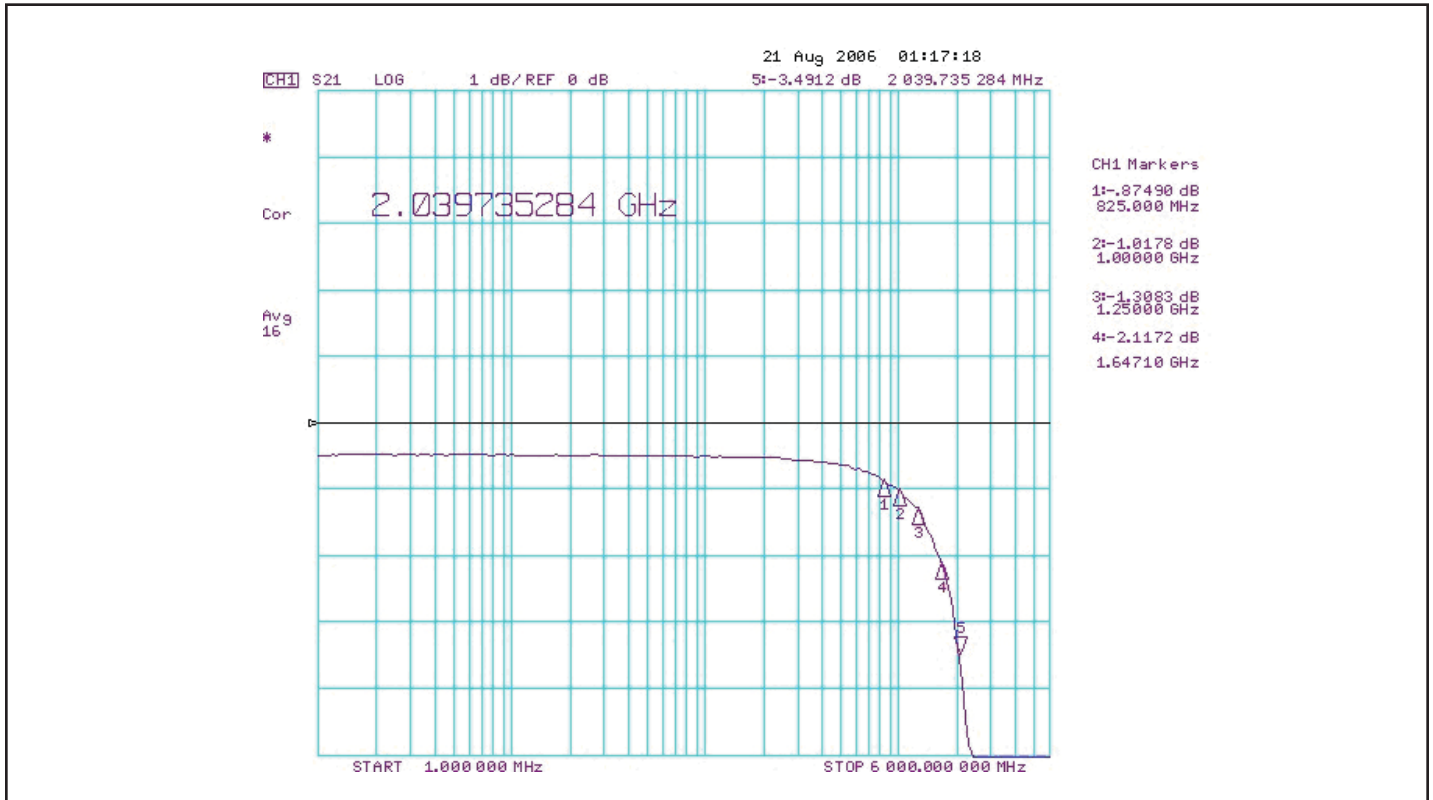
**Fig 2. Off-isolation setup**



**Fig 3. Crosstalk**

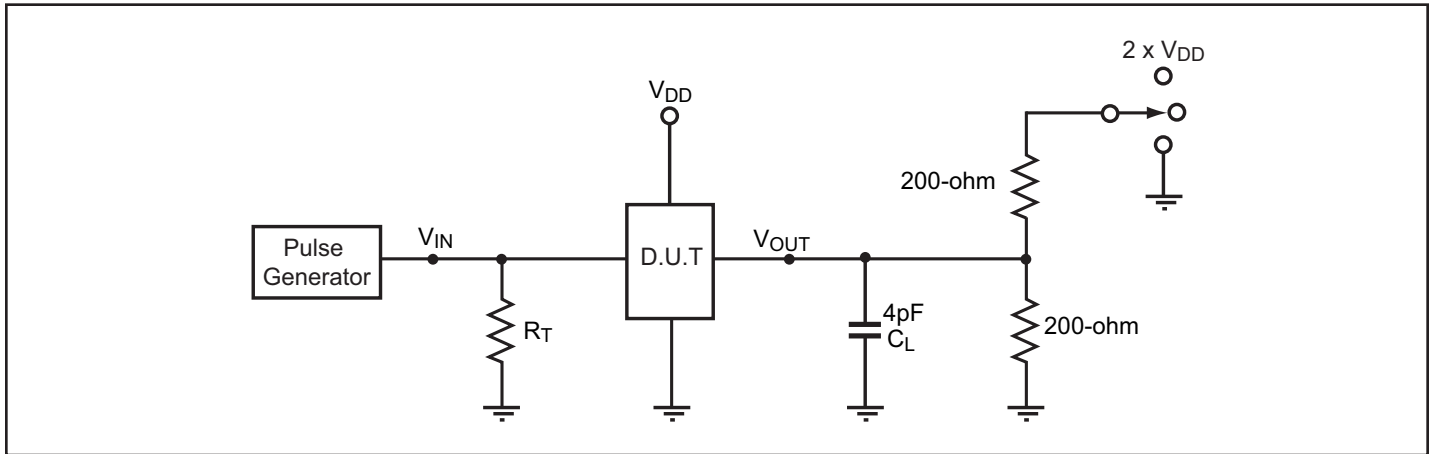


**Fig 4. Off Isolation**



**Fig 5. Bandwidth Plot**

### Test Circuit for Electrical Characteristics<sup>(1)</sup>



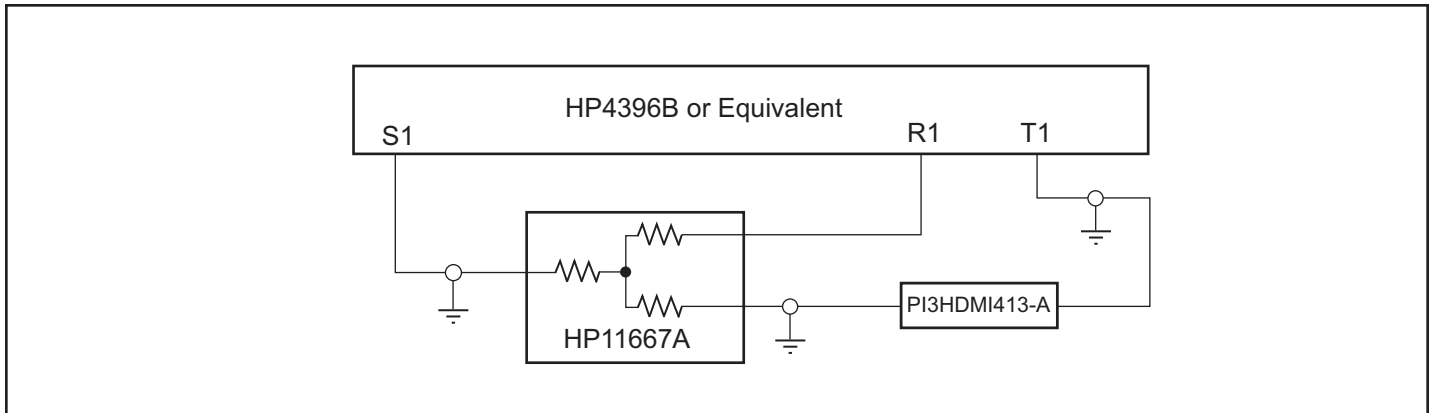
**Notes:**

1.  $C_L$  = Load capacitance: includes jig and probe capacitance.
2.  $R_T$  = Termination resistance: should be equal to  $Z_{OUT}$  of the Pulse Generator
3. Waveform 1 is for an output with internal conditions such that the output is low except when disabled by the output control.  
Waveform 2 is for an output with internal conditions such that the output is high except when disabled by the output control.
4. All input impulses are supplied by generators having the following characteristics:  $PRR \leq \text{MHz}$ ,  $Z_O = 50\Omega$ ,  $t_R \leq 2.5\text{ns}$ ,  $t_F \leq 2.5\text{ns}$ .
5. The outputs are measured one at a time with one transition per measurement.

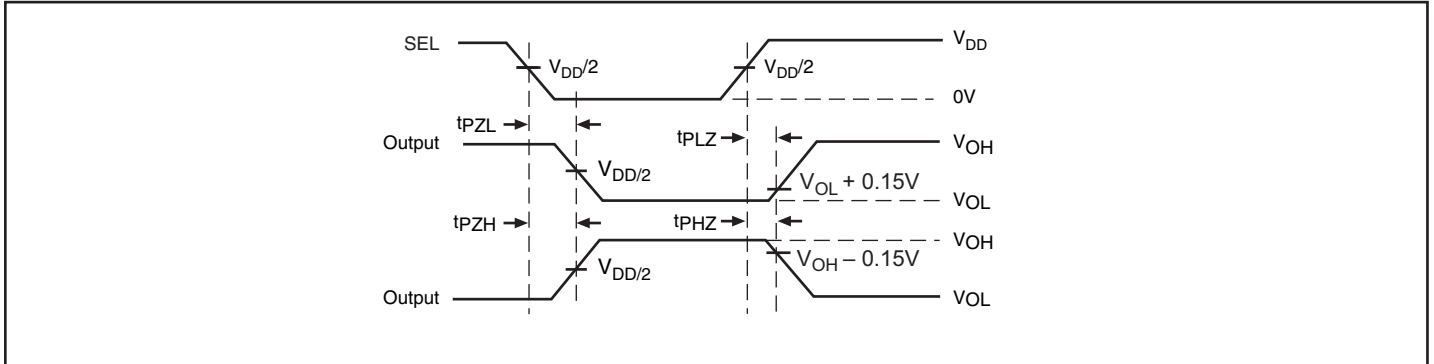
### Switch Positions

Test	Switch
$t_{PLZ}$ , $t_{PZL}$ (output on B-side)	$2 \times (V_{DD} - V_{SS})$
$t_{PHZ}$ , $t_{PZH}$ (output on B-side)	$V_{SS}$
Prop Delay	Open

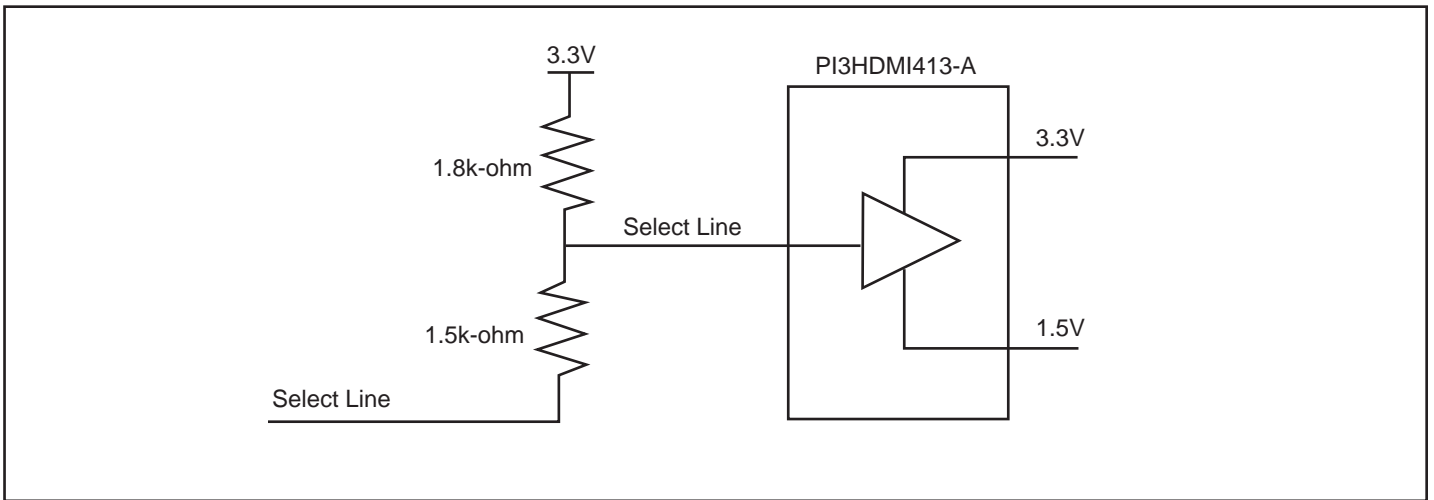
### Test Circuit for Dynamic Electrical Characteristics



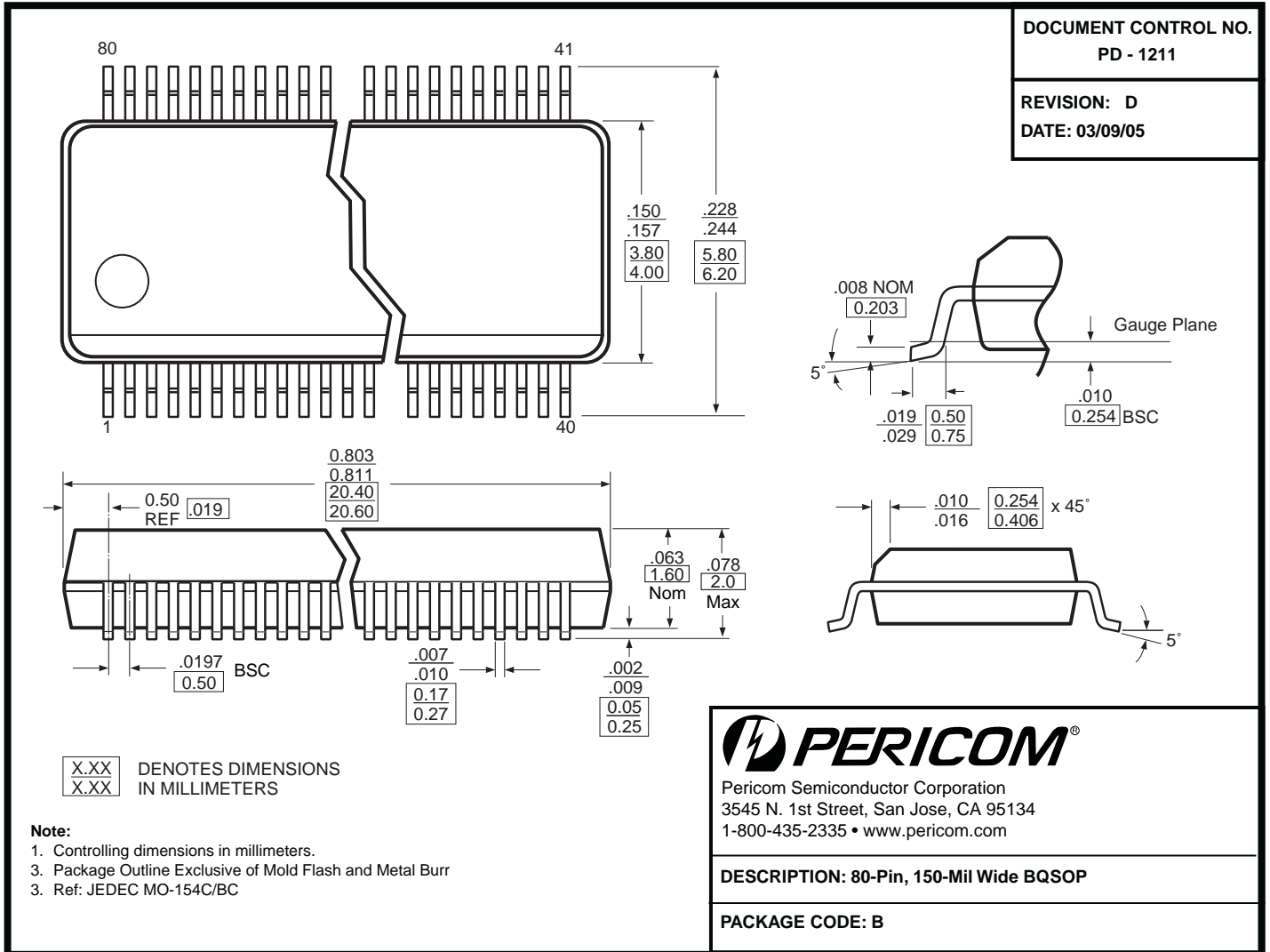
### Switching Waveforms



**Voltage Waveforms Enable and Disable Times**



**Example of a circuit that needs to be connected to the select lines of our device:**



**Note:**

- For latest package info, please check: <http://www.pericom.com/products/packaging/mechanicals.php>

**Ordering Information**

Ordering Code	Package Code	Package Description
PI3HDMI413-ABE	B	Pb-free & Green, 80-pin BQSOP

**Notes:**

- Thermal characteristics can be found on the company web site at [www.pericom.com/packaging/](http://www.pericom.com/packaging/)
- E = Pb-free & Green
- Adding X suffix = Tape/Reel