

3.2Gbps, 4 Differential Channel, Serial Re-Driver with Equalization, De-emphasis, and Squelch

Features

- Supports data rates up to 3.2Gbps on each lane
- Adjustable Transmitter De-Emphasis & Amplitude
- Adjustable Receiver Equalization
- Two Spread Spectrum Reference Clock Buffer Outputs
- Input signal level detection & output squelch on all channels
- 100Ω Differential CML I/O's
- Low Power (100mW per Channel)
- Standby Mode – Power Down State
- V_{CC} Operating Range: 1.8V +/-0.1V
- Packaging (Pb-free & Green): 84-ball LFBGA (NB84)

Description

Pericom Semiconductor's PI2EQX3202A is a low power, signal Re-Driver. The device provides programmable equalization, amplification, and de-emphasis by using 7 select bits, SEL[0:6], to optimize performance over a variety of physical mediums by reducing Inter-symbol interference. PI2EQX3202A supports four 100 Differential CML data I/O's between the Protocol ASIC to a switch fabric, across a backplane, or extends the signals across other distant data pathways on the user's platform.

The integrated equalization circuitry provides flexibility with signal integrity of the signal before the Re-Driver. Whereas the integrated de-emphasis circuitry provides flexibility with signal integrity of the signal after the Re-Driver.

A low-level input signal detection and output squelch function is provided for all four channels. Each channel operates fully independently. When a channel is enabled (EN_x=1) and operating, that channel input signal level (on xI+/-) determines whether the output is enabled. If the input level of the channel falls below the active threshold level (V_{th}-) then the output driver switches off, and the pin is pulled to VDD via a high impedance resistor.

In addition to providing signal re-conditioning, Pericom's PI2EQX3202A also provides power management Stand-by mode operated by an Enable pin.

Block Diagram

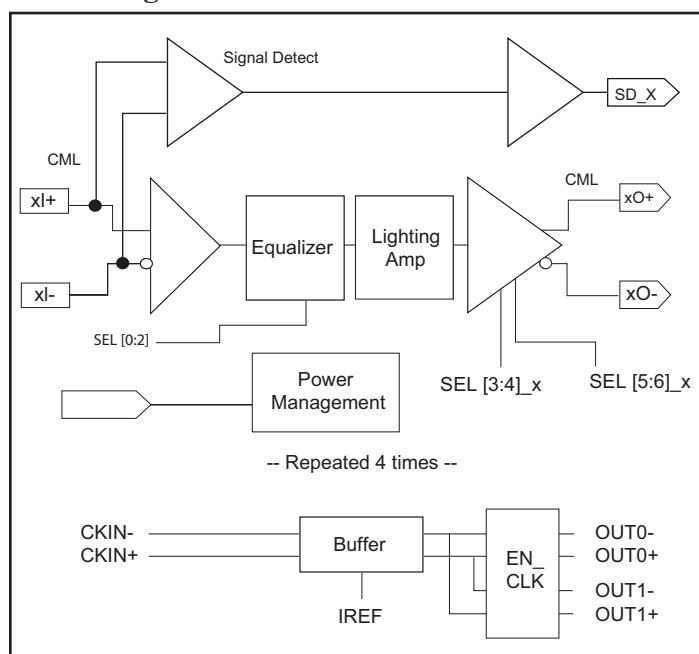

Pin Description

	1	2	3	4	5	6	7	8	9	10
A	SD_A	SD_B	SEL0_A	SEL0_B	SEL4_A	SEL4_B	SEL6_A	SEL6_B	EN_A	EN_B
B	V _{DD}	SD_C	V _{DD}	SEL1_A	SEL2_A	SEL3_A	SEL5_A	V _{DD}	EN_C	V _{DD}
C	BO+	SD_D	AI+	SEL1_B	SEL2_B	SEL3_B	SEL5_B	BI+	EN_D	AO+
D	BO-	V _{DD}	AI-	84-Ball LFBGA				BI-	GND	AO-
E	GND	V _{DD}	GND					GND	GND	GND
F	V _{DD}	GND	V _{DD}					V _{DD}	GND	V _{DD}
G	DO+	SEL0_C	CI+					DI+	SEL6_C	CO+
H	DO-	SEL0_D	CI-	V _{DD}	CKIN+	CKIN-	GND	DI-	SEL6_D	CO-
J	GND	SEL1_C	GND	SEL2_C	SEL2_D	SEL3_D	IREF	GND	SEL4_D	GND
K	EN_CLK	SEL1_D	SEL3_C	SEL4_C	OUT0+	OUT0-	OUT1+	OUT1-	SEL5_C	SEL5_D

Pin Description

Pin #	Pin Name	I/O	Description
B1, F1, D2, E2, B3, F3, H4, B8, F8, B10, F10	V _{DD}	PWR	1.8V Supply Voltage
C3	AI+	I	Positive CML Input Channel A with internal 50Ω pull down
D3	AI-	I	Negative CML Input Channel A with internal 50Ω pull down
E1, J1, F2, E3, J3, H7, E8, J8, D9, E9, F9, E10, J10	GND	PWR	Supply Ground
C8	BI+	I	Positive CML Input Channel B with internal 50Ω pull down
D8	BI-	I	Negative CML Input Channel B with internal 50Ω pull down
G3	CI+	I	Positive CML Input Channel C with internal 50Ω pull down
H3	CI-	I	Negative CML Input Channel C with internal 50Ω pull down
G8	DI+	I	Positive CML Input Channel D with internal 50Ω pull down
H8	DI-	I	Negative CML Input Channel D with internal 50Ω pull down
A3, B4, B5	SEL[0:2]_A	I	Selection pins for equalizer (see Amplifier Configuration Table) w/ 50kΩ internal pull up
A4, C4, C5	SEL[0:2]_B	I	
G2, J2, J4	SEL[0:2]_C	I	
H2, K2, J5	SEL[0:2]_D	I	
B6, A5	SEL[3:4]_A	I	Selection pins for amplifier (see Amplifier Configuration Table) w/ 50kΩ internal pull up
C6, A6	SEL[3:4]_B	I	
K3, K4	SEL[3:4]_C	I	
J6, J9	SEL[3:4]_D	I	
B7, A7	SEL[5:6]_A	I	Selection pins for De-Emphasis (See De-Emphasis Configuration Table) w/ 50kΩ internal pull up
C7, A8	SEL[5:6]_B	I	
K9, G9	SEL[5:6]_C	I	
K10, H9	SEL[5:6]_D	I	
C10	AO+	O	Positive CML Output Channel A internal 50Ω pull up during normal operation and 2kΩ pull up otherwise.
D10	AO-	O	Negative CML Output Channel A with internal 50Ω pull up during normal operation and 2kΩ pull up otherwise.
C1	BO+	O	Positive CML Output Channel B with internal 50Ω pull up during normal operation and 2kΩ pull up otherwise.
D1	BO-	O	Negative CML Output Channel B with internal 50Ω pull up during normal operation and 2kΩ pull up otherwise.
G10	CO+	O	Positive CML Output Channel C with internal 50Ω pull up during normal operation and 2kΩ pull up otherwise.
H10	CO-	O	Negative CML Output Channel C with internal 50Ω pull up during normal operation and 2kΩ pull up otherwise.
G1	DO+	O	Positive CML Output Channel D with internal 50Ω pull up during normal operation and 2kΩ pull up otherwise.
H1	DO-	O	Negative CML Output Channel D with internal 50Ω pull up during normal operation and 2kΩ pull up otherwise.

Pin Description (Continued)

Pin #	Pin Name	I/O	Description
A9, A10, B9, C9	EN_ [A,B,C,D]	I	Active HIGH LVCMOS signal input pins, when HIGH, it enables the CML output. When LOW, it disables the CML output (x0+, x0-) to HI-z state. Both x0+ & x0- outputs will be pulled up to V _{DD} by internal 2kΩ resistor.
H6	CKIN-	I	Differential Input Reference Clock
H5	CKIN+	I	
K5, K6	OUT0+, OUT0-	O	Differential Reference Clock Output
K7, K8	OUT1+, OUT1-	O	
J7	IREF	O	External 475Ω resistor connection to set the differential output current
K1	EN_CLK	I	Active HIGH LVCMOS signal input pin. When HIGH, it enables the OUT _x + / OUT _x - outputs. When LOW, it disables these outputs, to HI-z state. These outputs will be pulled down by external 50Ω termination resistor in application circuit.
A1, A2, B2, C2	SD_ [A,B,C,D]	O	Signal detected, channels A, B, C, D. Provides a LVCMOS high output when a valid input signal is detected. When low, SD _X indicates the input signal level is below the signal detect threshold level.

Maximum Ratings

(Above which useful life may be impaired. For user guidelines, not tested.)

Storage Temperature.....	-65°C to +150°C
Supply Voltage to Ground Potential.....	-0.5V to +2.5V
DC SIG Voltage.....	-0.5V to V _{CC} +0.5V
Current Output.....	-25mA to +25mA
Power Dissipation Continuous.....	800mW
Operating Temperature.....	0 to +70°C

Note:

Stresses greater than those listed under MAXIMUM RATINGS may cause permanent damage to the device. This is a stress rating only and functional operation of the device at these or any other conditions above those indicated in the operational sections of this specification is not implied. Exposure to absolute maximum rating conditions for extended periods may affect reliability.

Output Swing Control

SEL3_[A:D]	SEL4_[A:D]	Swing
0	0	1x
0	1	0.8x
1	0	1.2x
1	1	1.4x

Output De-emphasis Adjustment

SEL5_[A:D]	SEL6_[A:D]	De-emphasis
0	0	0dB
0	1	-2.5dB
1	0	-3.5dB
1	1	-4.5dB

Equalizer Selection

SEL0_[A:D]	SEL1_[A:D]	SEL2_[A:D]	Compliance Channel
0	0	0	No Equalization
0	0	1	[0:1.5dB] @ 1.6 GHz
0	1	0	[0:2.5dB] @ 1.6 GHz
0	1	1	[0:3.5dB] @ 1.6 GHz
1	0	0	[0:4.5dB] @ 1.6 GHz
1	0	1	[0:5.5dB] @ 1.6 GHz
1	1	0	[0:6.5dB] @ 1.6 GHz
1	1	1	[0:7.5dB] @ 1.6 GHz

AC/DC Electrical Characteristics for 2.5 Gbps Quad Repeater/Equalizer ($V_{DD} = 1.8 \pm 0.1V$)

Symbol	Parameter	Conditions	Min.	Typ.	Max.	Units
P _S	Supply Power	EN = LVCMOS Low			0.1	W
		EN = LVCMOS High			0.6	
	Latency	From input to output		2.0		ns
CML Receiver Input						
RL _{RX}	Return Loss	50 MHz to 1.25 GHz		12		dB
V _{RX-DIFFP-P}	Differential Input Peak-to-peak Voltage		0.200			V
V _{RX-CM-ACP}	AC Peak Common Mode Input Voltage				150	mV
V _{TH-}	Signal Detect Threshold	E _{N_X} = High	50		200	mV
Z _{RX-DIFF-DC}	DC Differential Input Impedance		80	100	120	Ω
Z _{RX-DC}	DC Input Impedance		40	50	60	
Equalization						
J _{RS}	Residual Jitter ^(1,2)	Total Jitter			0.3	Ulp-p
		Deterministic jitter			0.2	
J _{RM}	Random Jitter ^(1,2)			1.5		psrms

Notes

1. K28.7 pattern is applied differentially at point A as shown in Figure 1.
2. Total jitter does not include the signal source jitter. Total jitter (TJ) = (14.1 × RJ + DJ) where RJ is random RMS jitter and DJ is maximum deterministic jitter. Signal source is a K28.5 ± pattern (00 1111 1010 11 0000 0101) for the deterministic jitter test and K28.7 (0011111000) or equivalent for random jitter test. Residual jitter is that which remains after equalizing media-induced losses of the environment of Figure 1 or its equivalent. The deterministic jitter at point B must be from media-induced loss, and not from clock source modulation. Jitter is measured at 0V at point C of Figure 1.

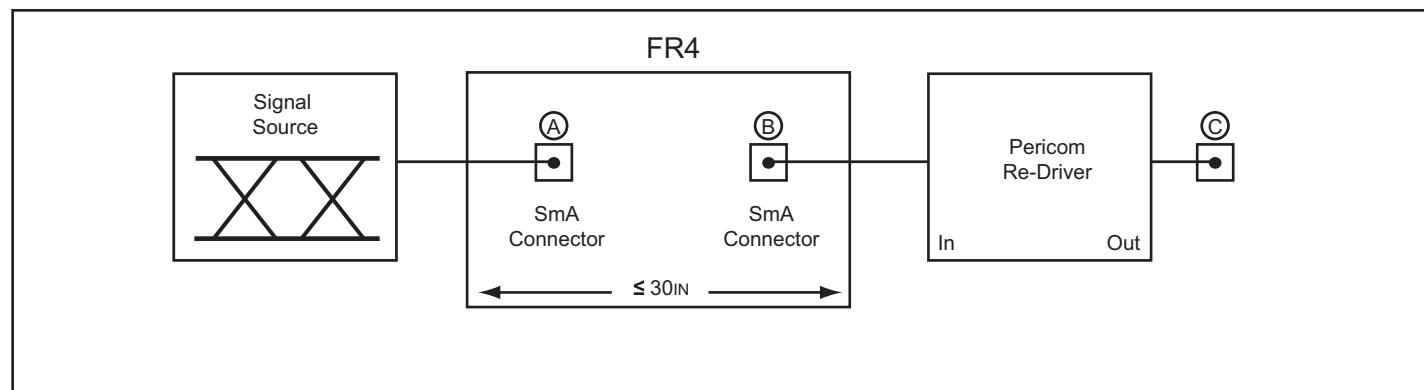

Figure 1. Test Condition Referenced in the Electrical Characteristic Table

AC/DC Electrical Characteristics for 2.5 Gbps x2 Lane Repeater/Equalizer (TA = 0 to 70°C)

Symbol	Parameter	Conditions	Min.	Typ.	Max.	Units
CML Transmitter Output (100Ω differential)						
V _{DIFFP}	Output Voltage Swing	Differential Swing V _{TX-D+} - V _{TX-D-}	400		700	mVp-p
V _{TX-C}	Common-Mode Voltage	V _{TX-D+} + V _{TX-D-} / 2		V _{CC} -0.3		
t _F , t _R	Transition Time	20% to 80% ⁽¹⁾			150	ps
Z _{OUT}	Output resistance	Single ended	40	50	60	Ω
Z _{TX-DIFF-DC}	DC Differential TX Impedance		80	100	120	Ω
C _{TX}	AC Coupling Capacitor		75		200	nF
V _{TX-DIFFP-P}	Differential Peak-to-peak Output Voltage	V _{TX-DIFFP-P} = 2 * V _{TX-D+} - V _{TX-D-}	0.8 ⁽²⁾		1.4 ⁽³⁾	V
LVC MOS Control Pins						
V _{IH}	Input High Voltage		0.65 × V _{DD}		V _{DD}	V
V _{IL}	Input Low Voltage				0.35 × V _{DD}	
I _{IH}	Input High Current				250	μA
I _{IL}	Input Low Current				500	

Note:

1. Using K28.7 (0011111000) pattern)
2. When 0.8x swing is selected.
3. When 1.4x swing is selected.

AC Switching Characteristics for Clock Buffer ($V_{DD} = 1.8 \pm 0.1V$, $AV_{DD} = 1.8 \pm 0.1V$) ⁽³⁾

Symbol	Parameters	Min	Max.	Units	Notes
T_{rise} / T_{fall}	Rise and Fall Time (measured between 0.175V to 0.525V) ⁽¹⁾	125	525	ps	1
$\square T_{rise} / \square T_{fall}$	Rise and Fall Time Variation		75		1
V_{HIGH}	Voltage High including overshoot	660	900	mV	1
V_{LOW}	Voltage Low including undershoot	-150			1
V_{CROSS}	Absolute crossing point voltages	-200	550		1
$\square V_{CROSS}$	Total Variation of V_{cross} over all edges	200	250		1
T_{DC}	Duty Cycle (input duty cycle = 50%) ⁽²⁾	45	55	%	2

Notes:

1. Measurement taken from Single Ended waveform.
2. Measurement taken from Differential waveform.
3. Test configuration is $R_S = 33.2\Omega$, $R_p = 49.9\Omega$, and 2pF.

Configuration Test Load Board Termination

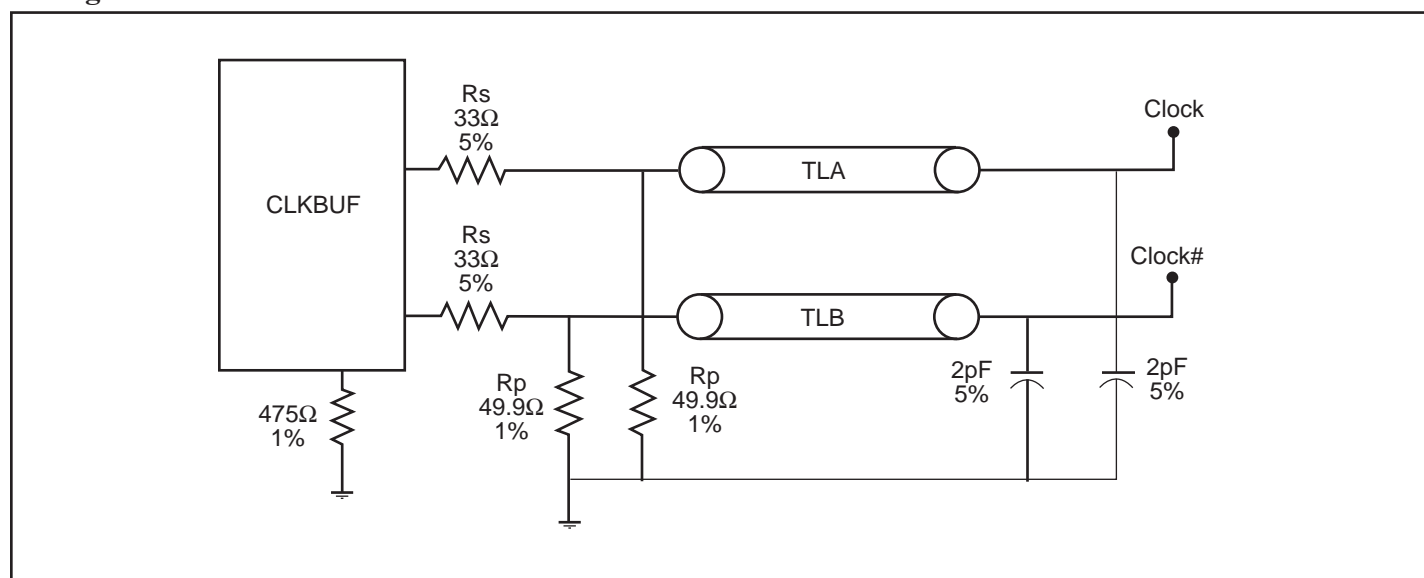
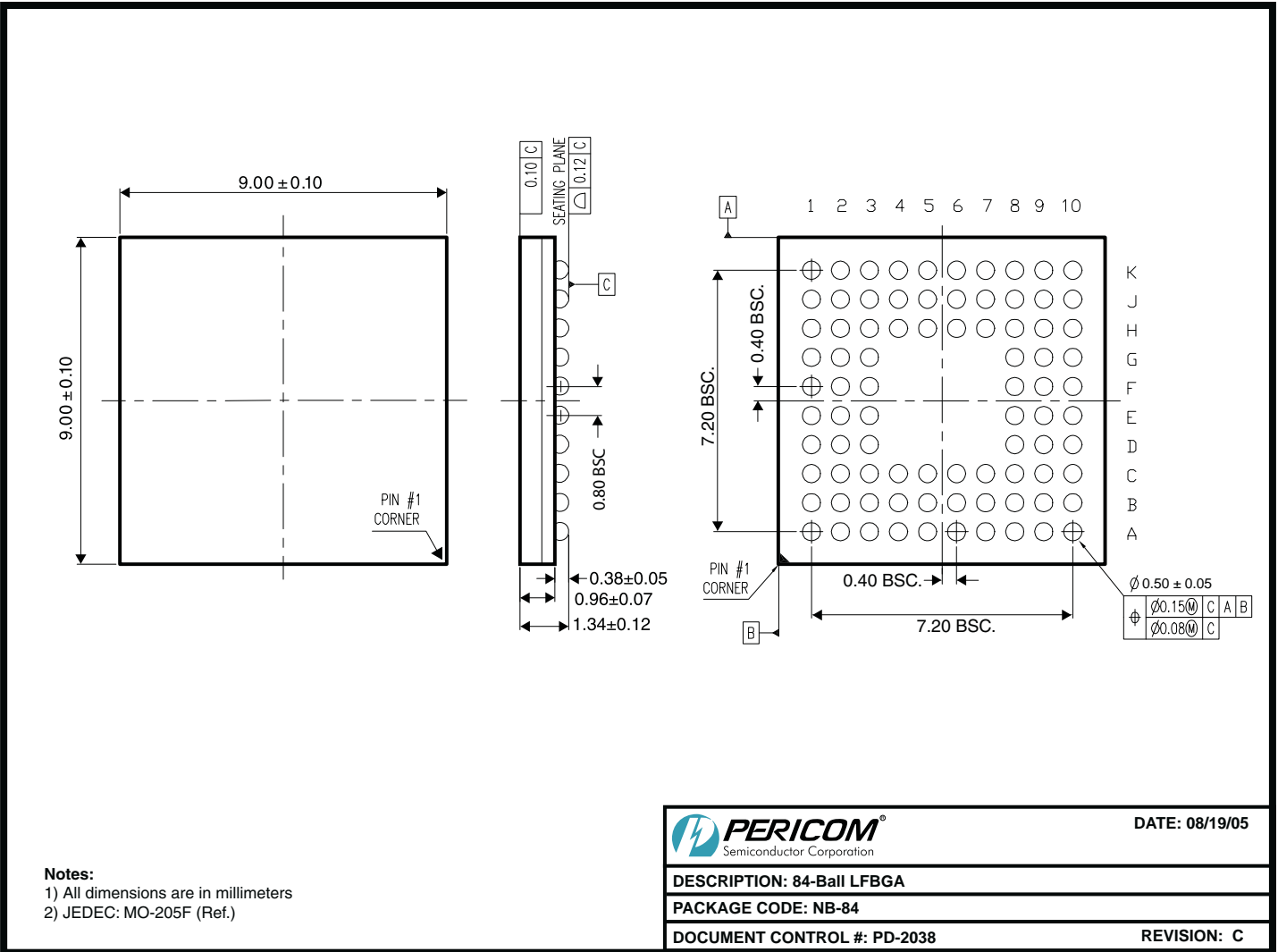

Figure 2. Configuration test load board termination

Note:

- TLA and TLB are 3" transmission lines.



Ordering Information

Ordering Number	Package Code	Package Description
PI2EQX3202ANBE	NB	Pb-free & Green 84-Ball LFBGA

Notes:

- Thermal characteristics can be found on the company web site at www.pericom.com/packaging/
- E = Pb-free and Green
- X suffix = Tape/Reel