

USB Sleep and Charge Switch for Single USB Port with Automatic Switching
Features

- ➔ Enables USB device to draw current from Vbus when USB enumeration is not available
- ➔ Protects USB path from direct shortage to Vbus
- ➔ Provides full ESD support on exposed I/O pins per IEC61000-4-2 specification up to level 2 ($\pm 4\text{kV}$ contact)
- ➔ Provides multiple modes of charging to ensure all of the following spec's can be met:
 - USB 1.0 charger spec, USB 1.1 charger spec, and YD/T-1591 charger spec
 - Certain modes available can also support devices using non-standard approach to charging, such as Apple products.
 - The following devices have been proven to be supported with at least one of the PI5USB56 charging modes.
 - ➔ Nokia, Samsung, LGE, HTC, Blackberry, Apple iPod, Apple iPhone, China models, Palm Pre
- ➔ Automatically switch between modes by detecting correctly plugged in device
- ➔ 5V power supply
- ➔ Ability to enable/disable external power switch when charging is not required
- ➔ Low power consumption to support Energy Star Compliance
- ➔ Packaging (Pb-free & Green):
 - 24-Pin QSOP, 24-Contact TQFN

Description

Notebook PCs are used around the world to charge battery-powered handheld devices such as cell phones and MP3/MP4 players. Handheld devices require communication with the notebook PC before they start to draw current. This ensures that the handheld device will obtain sufficient current when it wants to charge. The issue is that the notebook PC does not have a way to provide this acknowledge signal to the handheld device when the notebook is in "Sleep" mode.

Pericom's PI5USB56 solves this issue by setting the D+/D- pins in the notebook PC to the required signal levels during "sleep" mode. When the handheld device sees these required signal levels, it will then start to draw the current required to charge itself.

Cell phones within today's market use different communication schemes, therefore the switch will need to configure itself in different modes. PI5USB56 can alternate between modes automatically, once device type is correctly detected.

All signal pins are protected with Pericom's ESD protection circuits supporting ESD damage as high as 4kV contact per IEC61000-4-2 Level 2 specification.

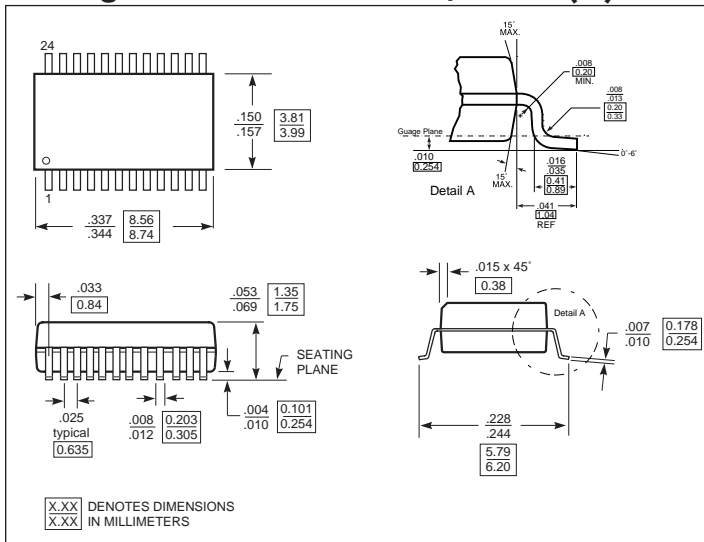
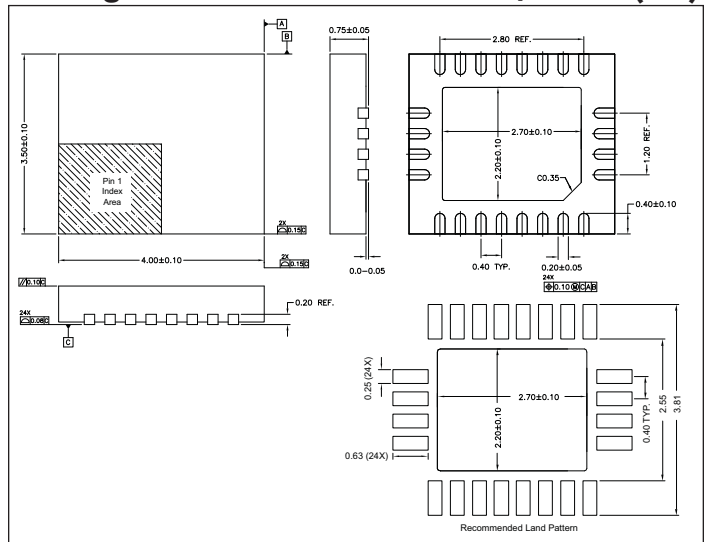
Package Mechanical: 24-Pin, QSOP (Q)

Package Mechanical: 24-Contact, TQFN (ZK)

Ordering Information

Ordering Code	Package Code	Package Type
PI5USB56QE	Q	Pb-free & Green, 24pin 150 mil wide QSOP
PI5USB56ZKE	ZK	Pb-free & Green, 24contact TQFN

1. Thermal characteristics can be found on the company web site at www.pericom.com/packaging/
2. E = Pb-free and Green
3. Adding an X Suffix = Tape/Reel