

TOP VIEW

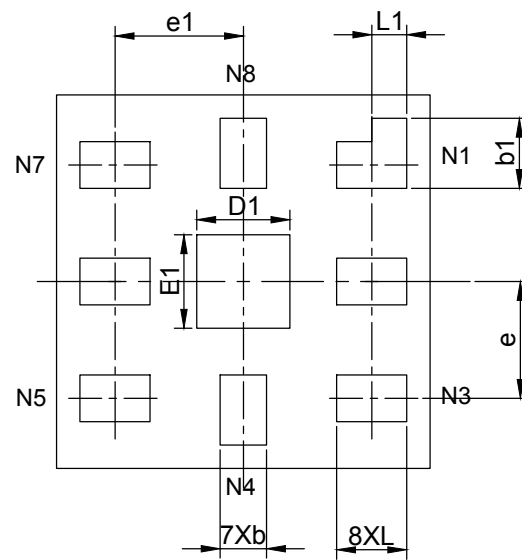

BOTTOM VIEW

PKG. DIMENSIONS(MM)		
SYMBOL	Min	Max
A	0.45	0.55
A1	0.00	0.05
A3	0.15 REF	
D	1.55	1.65
E	1.55	1.65
D1	0.30	0.50
E1	0.30	0.50
b	0.15	0.25
e	0.50 TYP	
e1	0.55 TYP	
L	0.25	0.35
b1	0.25	0.35
L1	0.15 REF	

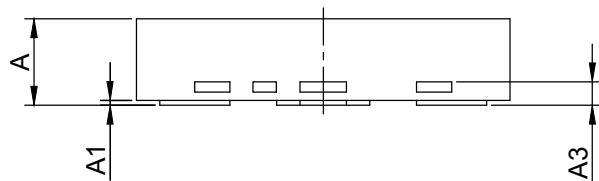

SIDE VIEW

Note:

1. Ref: JEDEC MO-288B



DATE: 06/18/13

DESCRIPTION: 8-Pin, UQFN, 1.6X1.6, COL

PACKAGE CODE: XT (XT8)

DOCUMENT CONTROL #: PD-2132

REVISION: --